

20X-10

1/10TH SCALE 2WD ELECTRIC RACE BUGGY



FURY

1/10TH SCALE 2WD ELECTRIC SHORT COURSE TRUCK



GRANITE

1/10TH SCALE 2WD ELECTRIC MONSTER TRUCK



MOJAVE

1/10 ELECTRIC 2WD DESERT TRUCK



RANGER

1/10TH SCALE 2WD ELECTRIC DESERT BUGGY



VORIEKS

1/10TH SCALE 2WD ELECTRIC STADIUM TRUCK



'ARRMA'

DESIGNED FAST DESIGNED TOUGH



Contents

	Page		Page
WARNINGS	3	FACTORY CHASSIS SETTINGS	17
KIT OVERVIEW	3	CHASSIS TUNING	19
REQUIRED	4	Ride Height	19
BATTERY CHARGING	4	Camber Link Length	19
Safety Instructions for Batteries	5	Steering Arm Length (Toe In/Out)	19
CHASSIS OVERVIEW	5	Camber Link Position	19
RADIOGEAR	6	Shock Position	19
Overview	6	Shock Removal	20
Steering Trim	6	Springs	20
Throttle Trim	6	Shock Oil	20
Binding	6	DRIVETRAIN TUNING	21
Dual Rate	7	Gear Chart	21
Battery Status	7	Spur/Pinion Gear Removal	21
Factory Defaults	7	Motor Removal	22
FCC Details	7	Differential Tuning	22
ELECTRONIC SPEED CONTROL (ESC)	7	Differential Removal	23
Specifications	7	Differential Exploded View	24
Overview	7	RADIO-GEAR MAINTENANCE	25
Throttle Setup	7	Receiver Access	25
ESC Status LED	8	STEERING MAINTENANCE	25
Temperature Protection	8	Steering Access	25
ESC Tuning & Factory Defaults	8	Servo Removal	26
BATTERY FITTING	9	EXPLODED VIEWS	27
RUNNING	9	OPTION PARTS AND UPGRADES	37
DRIVING FUNDAMENTALS	9	BLANK CHASSIS SETUP SHEETS	38
POST-DRIVE CHECKS	9		
MAINTENANCE	10		
Recommended Tools	10		
Trouble Shooting Matrix	10		
Maintenance Schedule	11		
Chassis Maintenance	12		
Wheel and Tyre Maintenance	12		
Slipper Clutch Adjustment	13		
Spur/Pinion Mesh Adjustment	13		
Slipper Pad Replacement	14		
Driveshaft Maintenance	15		
Rear Axle Maintenance	15		
Wheel Bearing Replacement	16		



Battery Mode Batteriemodus Mode de Batterie Modo de batería バッテリーモード 電池模式

If using LiPo batteries you must set the correct battery mode on the ESC (electronic speed controller) to prevent battery damage.

Wenn Sie LiPo-Akkus verwenden, muss der entsprechende Batteriemodus am Fahrtregler angewählt sein, um Schäden an der Batterie durch Tiefentladung zu verhindern.

Pour l'utilisation de batteries LiPo, vous devez définir le mode batterie correcte sur le ESC (contrôleur de vitesse électronique) pour prévenir les dommages de la batterie.

Si utiliza baterías LiPo deberá seleccionar el modo de batería correcto en el ESC (controlador electrónico de velocidad) para prevenir daños en las baterías.

LiPo バッテリーをご使用の場合は、バッテリーの損傷を防ぐため、ESC を適切なバッテリーモードに設定してください。

如果使用锂聚合物电池您必须设置对 ESC (电子调速器), 正确的电池模式, 以防止电池损坏。



Warning Achtung Avertissement Precaución 警告 警告

This is not a toy. This is a high performance RC model and must be treated with care and respect. It is the user's (your) responsibility to operate this product safely. It is necessary to be above 14 years of age to operate this model. It is the parents or guardians responsibility to ensure minors receive appropriate guidance. For further safety information and guidance please refer to your welcome pack online at ARRMA-RC.com/GO

Dieses komplexe rc-modell ist kein spielzeug und muss mit umsicht benutzt werden. Es obliegt dem benutzer (ihnen) dieses produkt ordnungsgemäss und sicher zu bedienen. Nicht für Kinder unter 14 Jahren geeignet. Es obliegt den erziehungsberechtigten, kinder bei der benutzung dieses produktes zu beaufsichtigen oder sie korrekt einzuweisen. Für weitere Sicherheitshinweise und Hilfestellung sehen Sie sich bitte unser Willkommenspaket unter ARRMA-RC.com/GO an.

Ce n'est pas un jouet. C'est un modèle radiocommande complexe, de haute performance qui doit être traité avec soin et respect. C'est à l'utilisateur (vous) qu'incombe d'exploiter ce produit en toute sécurité. Ne convient pas pour les enfants âgés de moins de 14 ans la surveillance d'un adulte. Il est de la responsabilité des parents ou des tuteurs de s'assurer que les mineurs reçoivent les conseils appropriés ou les directives lors de l'utilisation ou des interventions sur ce produit. Pour plus d'informations sur la sécurité et l'utilisation veuillez consulter votre pack de bienvenue en ligne sur le site ARRMA-RC.com/GO

Este producto no es un juguete. Este producto es un complejo modelo de radiocontrol de altas prestaciones y debe ser utilizado con precaución. Es responsabilidad del usuario (usted) el utilizar este producto en condiciones de seguridad apropiadas. No se recomienda para niños menores de 14 años sin la supervisión por parte de un adulto. En caso de menores de edad, es responsabilidad de los padres o tutores proporcionar la ayuda y/o supervisión apropiadas al utilizar o trabajar con este producto. Para más información y consejos de seguridad, por favor consulte su pack de bienvenida online en ARRMA-RC.com/GO

本製品はおもちゃではありません。本製品は高性能ラジオコントロールモデルカーです。取扱いには十分な注意が必要です。製品を安全にご使用いただく事はお客様の責任です。キットである為、14歳未満のお子様で使用される場合には必ず保護者の監督の下に使用してください。本製品をお子様で使用される際には必ず保護者の監視下で走行、メンテナンスを行ってください。安全にご使用いただく為にオンライン ARRMA-RC.com/GO 内のウェルカムバックにてガイドランスをご確認ください。

本产品不是玩具。这是一个结构复杂且高水准的遥控模型，使用上必须小心。安全地操作本产品是使用者(您)的责任。需要年满14岁以上才能操作此模型。当使用或组装本产品时，确保未成年使用者得到适当的指导以及监督，是父母或是监护人的责任。请上网 ARRMA-RC.com/GO 搜寻更多相关的安全信息以及指导。



Warranty Garantie Garantie Garantía 保証についての 保固

To guarantee you have the best experience ARRMA offer a 2 year warranty covering defects in materials, workmanship and assembly on all our products. To ensure you understand the full terms of the warranty and its limitations please refer to your welcome pack online at ARRMA-RC.com/GO.

Für maximale Freude an Ihrem Produkt bietet ARRMA eine Zweijahres-Garantie, die Materialdefekte und Fertigungsfehler einschliesst. Um sicherzustellen, dass Sie alle Garantiebedingungen kennen, schauen Sie sich bitte das Willkommenspaket auf ARRMA-RC.com/GO an.

Afin de vous assurer, la meilleure expérience, ARRMA offre une garantie de 2 ans, couvrant les défauts des matériaux, de fabrication et d'assemblage sur tous nos produits. Afin de vous assurer que vous comprenez les termes complets de la garantie et ses limites veuillez consulter votre pack de bienvenue en ligne sur le site ARRMA-RC.com/GO.

Para asegurarse la mejor experiencia posible, ARRMA le ofrece 2 años de garantía cubriendo defectos de materiales, producción o montaje en todos nuestros productos. Para asegurarse de que comprende todos los términos de la garantía y sus limitaciones, por favor consulte su pack de bienvenida online en ARRMA-RC.com/GO

安心してご使用いただく為に ARRMA は本製品に対し、2年間の製品品質不良及び工場での組立不良に対する保証を提供いたします。保証条件等の詳細につきましてはオンライン ARRMA-RC.com/GO 内のウェルカムバックに記載されておりますので製品のご使用前にご確認ください。

为了保证您拥有最棒的体验, ARRMA 提供所有产品 2 年的保固, 包含材料以及组装上的瑕疵。为了确保您了解保固期限以及限制条件, 请上网 ARRMA-RC.com/GO 查询。



Support Hilfestellung Support Soporte サポート 支援

At ARRMA we want you to love running your kit and make owning a high performance RC car as simple as possible. If you have any questions about running, maintaining, tuning or repairing your ARRMA product there are three options for you to use to get help and advice. Visit ARRMA-RC.com for support, parts and upgrades for your kit. 'GO FOR IT' is the worldwide owner's forum for ARRMA. Here you will find other ARRMA owners, get help and advice on how to get the best from your ARRMA product. If you can't find what you're looking for then you can always email us at supportUSA@ARRMA-RC (USA) or support@ARRMA-RC.com (ROW) 24hrs a day and we will do our best to help you with your query.

Bei ARRMA möchten wir, dass Sie lange Freude an Ihrem High-Performance-RC-Modell haben. Sollten Sie Fragen zu Betrieb, Wartung, Tuning oder Reparatur haben, dann bieten wir eine Fülle von Möglichkeiten. Behen Sie auf arrma-rc.com, um mehr über Hilfestellung, Teile oder Tuningteile zu erfahren "GO FOR IT" ist ein weltweites Forum für die Benutzer und Eigner von ARRMA-Produkten. Hier finden Sie andere ARRMA-Nutzer, erhalten Hilfestellung und vieles mehr. Sollten Sie einmal keine Antworten finden, dann kontaktieren Sie uns über supportUSA@ARRMA-RC (USA) oder support@arrma-rc.com (ROW) und wir werden alles tun, um Ihnen helfen zu können.

Chez ARRMA notre volonté est que vous appréciiez faire évoluer votre voiture et vous faire posséder une modèle RC de haute performance aussi simple que possible. Si vous avez des questions concernant le fonctionnement, la maintenance, le réglage ou la réparation de votre produit ARRMA, il y a trois possibilité que vous pouvez utiliser pour obtenir l'aide et des conseils. Visitez ARRMA-RC.com pour la prise en charge, des pièces et des mises à niveau de votre kit. « GO FOR IT » est un forum de propriétaires de produit ARRMA dans le monde entier. Vous y retrouverez les autres propriétaires ARRMA, obtiendrez de l'aide et des conseils sur la façon de tirer le meilleur de votre produit ARRMA. Si vous ne trouvez pas ce que vous recherchez, vous pouvez toujours nous contacter par courriel à supportUSA@ARRMA-RC (USA) ou support@arrma-rc.com (ROW) 24h par jour et nous ferons de notre mieux pour vous aider dansvotre requête.

En ARRMA queremos que disfrute al utilizar su coche y que poseer un modelo de radiocontrol de altas prestaciones sea lo más fácil posible. Si tiene cualquier pregunta sobre utilización, mantenimiento, ajuste o reparación de su producto ARRMA dispone de tres opciones para obtener ayuda y consejo. Visite ARRMA-RC.com para obtener soporte técnico, recambios y mejoras para su modelo. 'GO FOR IT' es el foro internacional de usuarios de ARRMA. En él encontrará otros usuarios de ARRMA y podrá obtener ayuda y consejos para aprovechar al máximo su producto ARRMA. Si no encuentra lo que busca siempre podrá contactarnos por correo electrónico a supportUSA@ARRMA-RC (USA) o support@arrma-rc.com (ROW) donde haremos todo lo posible por ayudarle las 24 horas del día.

お客様には本製品の走行をお楽しみ頂き、できる限り簡単に高性能 RC にアップグレードして頂きたいと思ます。ARRMA 製品の走行、メンテナンス、チューニング、修理でご質問がある場合、当社では以下の 3 つの方法でアドバイスを ご提供しております。キットのサポートやパーツ、アップグレードについてはホームページ (ARRMA-RC.com) をご覧ください。GO FOR IT は世界中の ARRMA ユーザーのためのフォーラムで、他の ARRMA ユーザーの情報が掲載されており、ARRMA 製品についてのアドバイスが得られます。ホームページやフォーラムでお探しの情報が見つからない場合は当社まで Eメールでお問い合わせください (supportUSA@ARRMA-RC.com (USA) support@ARRMA-RC.com (ROW))。

在 ARRMA 世界里我们希望您能够喜爱操控玩您的车以及能够轻松拥有一台高水准的遥控模型。如果您有任何关于操控、保养、微调或修复您的 ARRMA 产品的问题, 我们提供您三个选项来帮助您以及给您建议。请上官网 ARRMA-RC.com 查询相关零件和升级的资讯。'GO FOR IT' 是全球 ARRMA 玩家的论坛。在这里您可以找到其他 ARRMA 玩家, 并寻求帮助及建议来让您的 ARRMA 产品呈现更好的状态。如果您找不到您想询问的问题, 您可以在任何时候写信到 supportUSA@ARRMA-RC.com (USA) support@ARRMA-RC.com (ROW), 我们将会尽全力帮助您解决您的疑虑。



Kit Overview

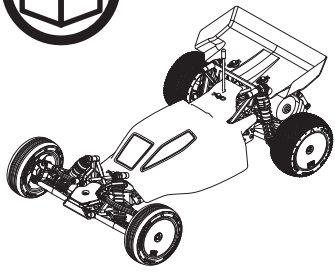

ARRMA ADX-10

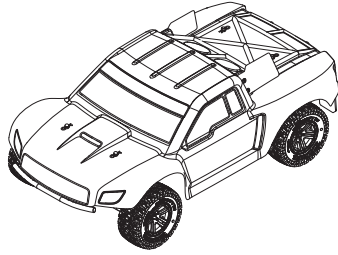

ARRMA Fury

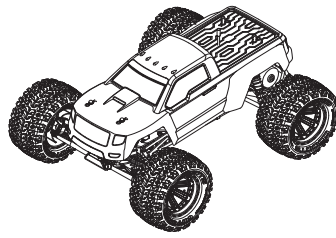

ARRMA Granite

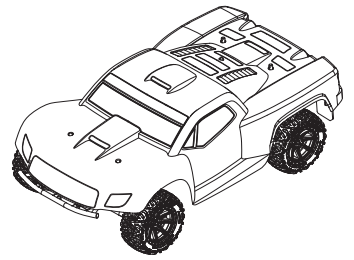

ARRMA Mojave

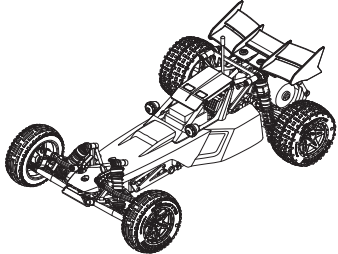

ARRMA Raider

US Design Patent application no. 29/392 417
Community Design No: 001275770-0001

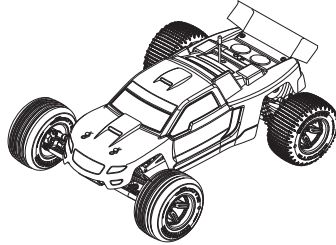

ARRMA Vorteks



Shock pre-load spacers

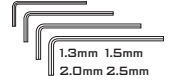

Hex Wrenches

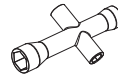

Cross wrench

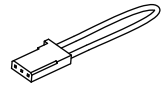

Receiver Bind Plug

Kit # 102530 > 102537 _ATY/CTY/GTY/ITY

Kit # 102530 > 102537 _TY

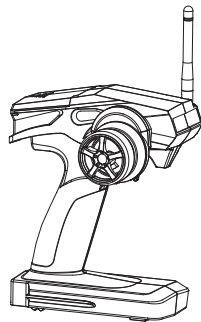

ARRMA ATX 2.4.Ghz
Transmitter

Kit # 102530 > 102537 _ATN/CTN/GTN/ITN

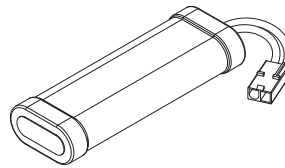

7.2V Battery and Charger

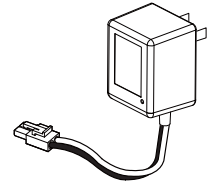

Required

Kit # 102540 > 102549 _TN

Kit # 102530 >
102537 _TY

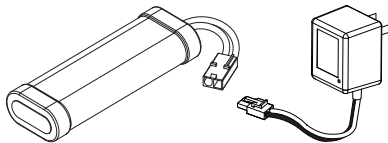

7.2/7.4V Battery and Charger

Kit # 102530 >
102537 _ATN



Radiogear

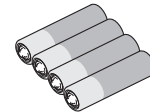
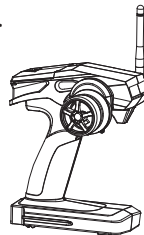

AA batteries
x4



PC with Internet
access



Battery Charging

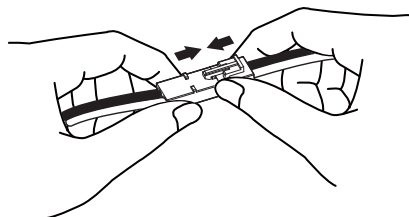
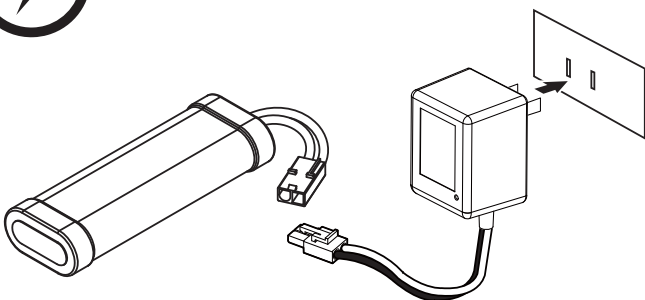

E.G 7.2V NiMH 3000MAH @700MA = 4.3 HOURS.

Safety Instructions for Batteries



CAUTION: RISK OF EXPLOSION IF BATTERY IS REPLACED BY AN INCORRECT TYPE. DISPOSE OF USED BATTERIES ACCORDING TO THE INSTRUCTIONS.

1. Use only four(4) AA alkaline batteries in your ATX100 transmitter.
2. Do not dispose of the battery in a fire as it may explode. Check with local codes for possible special disposal instructions.
3. Do not open or mutilate the battery. Released electrolyte is corrosive and may cause damage to the eyes and skin. It may be toxic if swallowed.
4. Exercise care in handling batteries in order not to short the battery with conducting materials such as rings, bracelets and keys. The battery or conduction material may over-heat and cause burns.



Chassis Overview

N.B. Vorteks chassis shown as an example - information applies to all variants.

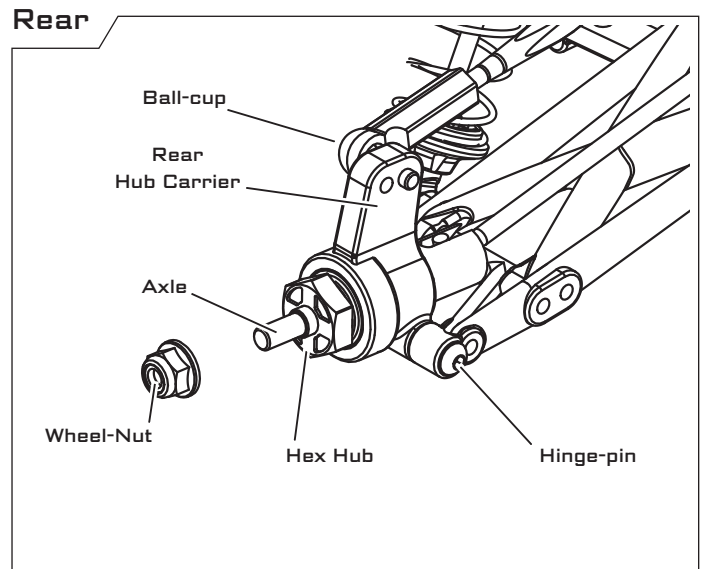
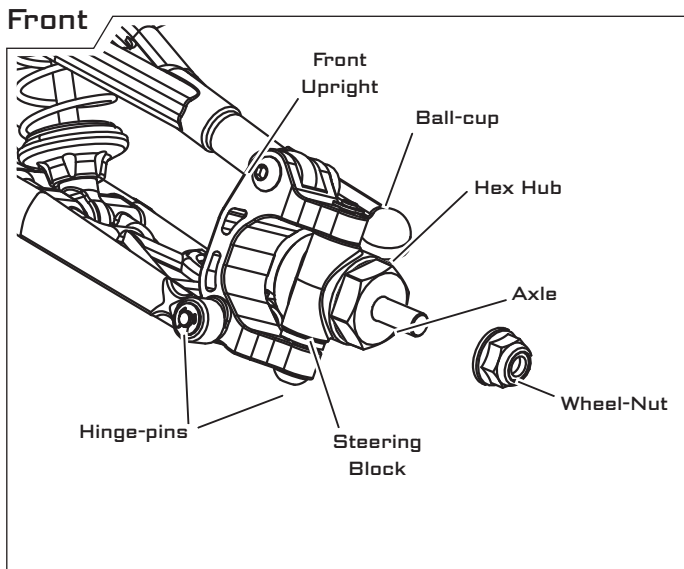
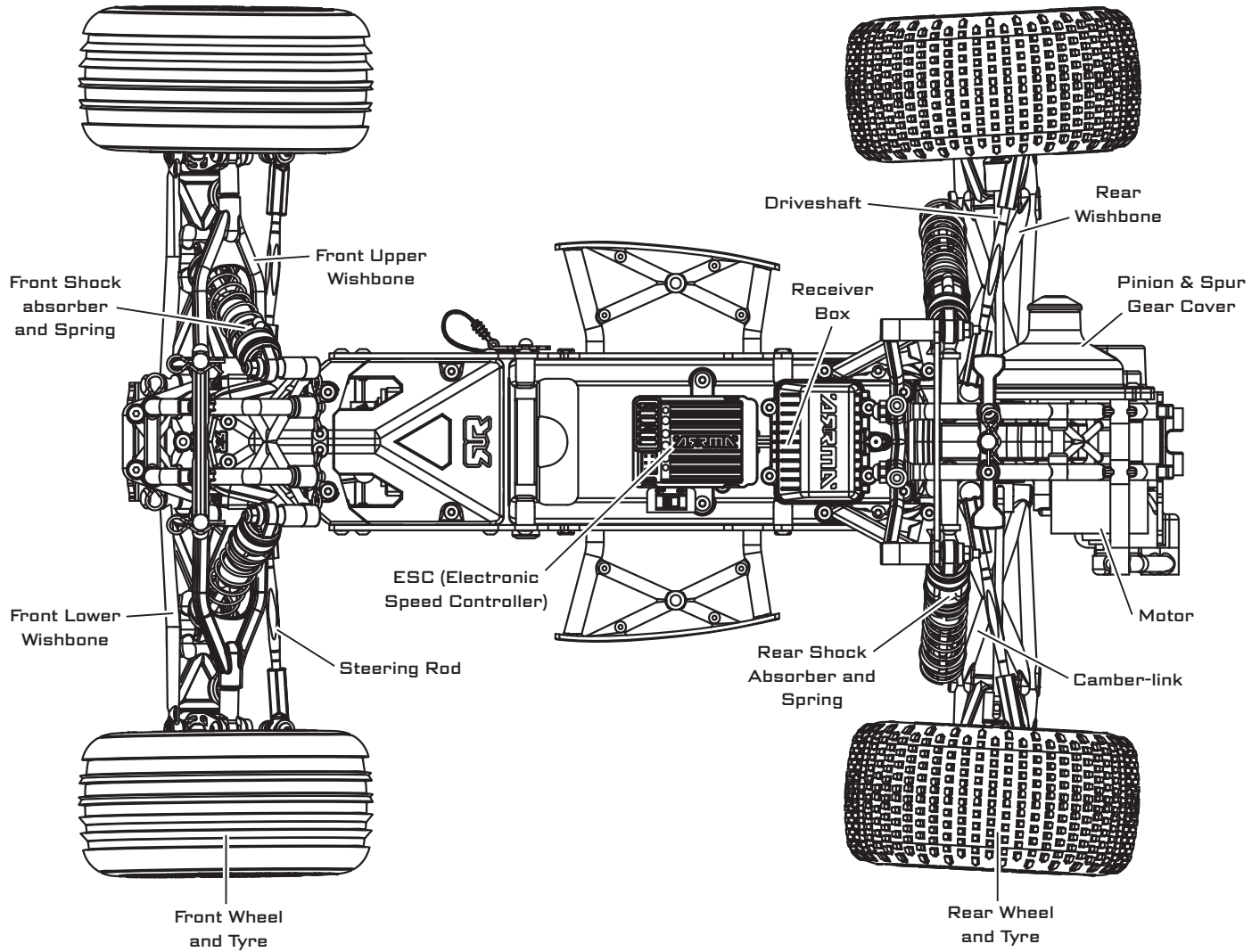



Radio Gear

ARRMA ATX100 2.4GHz

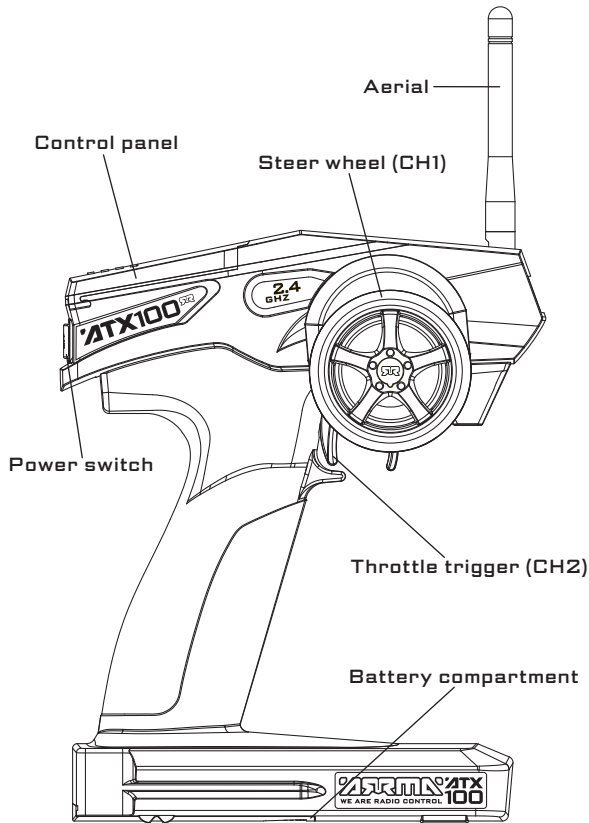

CONTROL PANEL

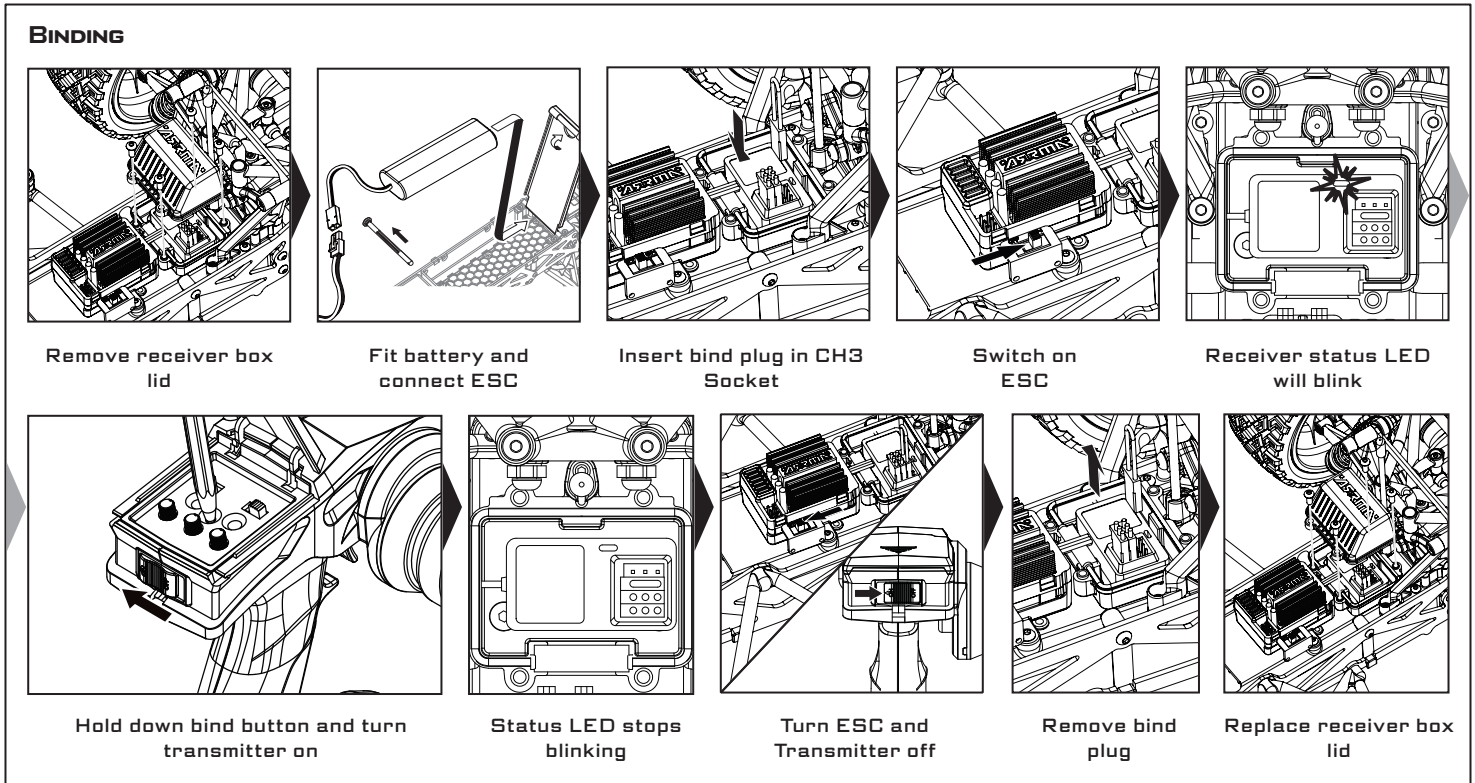
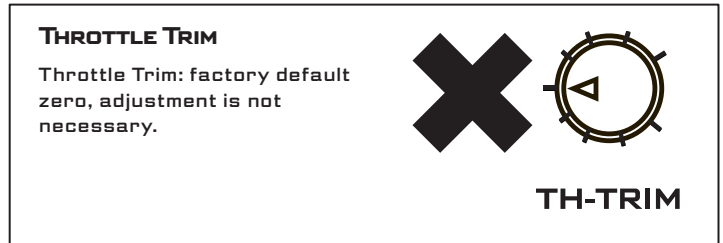
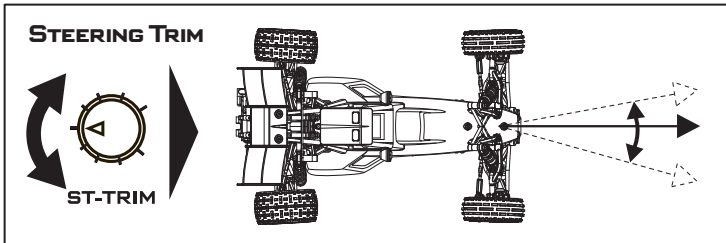
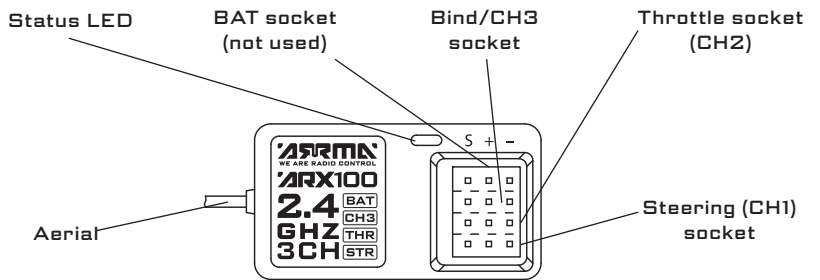
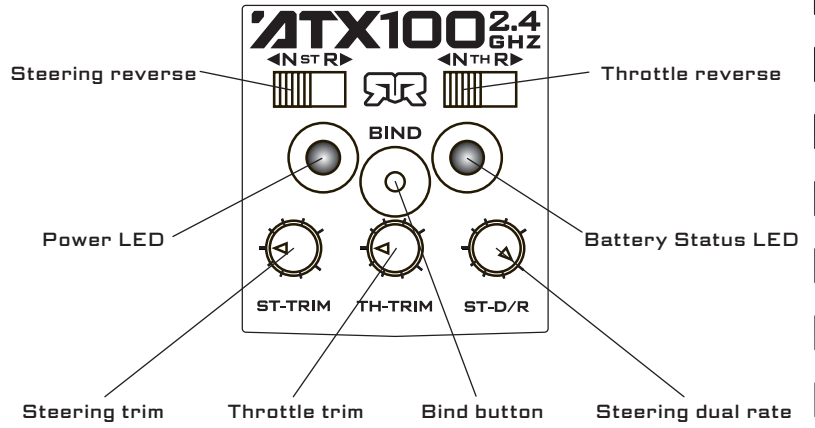

DUAL RATE

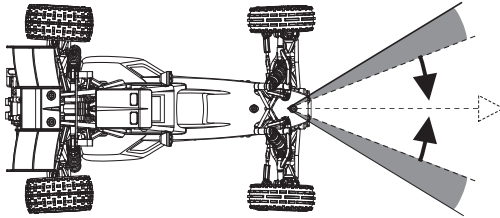
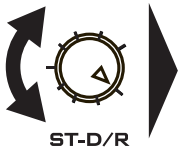

BATTERY STATUS

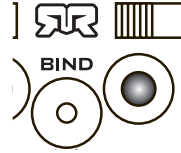

If battery status LED is flashing, the batteries need to be replaced.



FACTORY DEFAULTS

- Steering/throttle channels switches set to 'N',
- Steering and Throttle trim set to middle/zero adjustment.
- Steering Dual Rate at 100%/fully right.

CONTAINS FCC ID: ZL4-KST-HXGT2

This device complies with Part 15 of the FCC Rules. Operation is subject to the following conditions: (1) this device may not cause harmful interference, and (2) this device must accept any interference received, including interference that may cause undesired operation.



Electronic Speed Controller (ESC)



If using LiPo batteries you must set the correct battery mode on the ESC (electronic speed controller) to prevent battery damage.

ESC SPECIFICATIONS

Input Voltage	6-7 NiMh (7.2-8.4v) / 2S Lipo (7.4v)	BEC Output	5.0v/2A Max
---------------	--------------------------------------	------------	-------------

Motor wires
(Orange/Red +)
(Blue/Black -)

Heat-sink

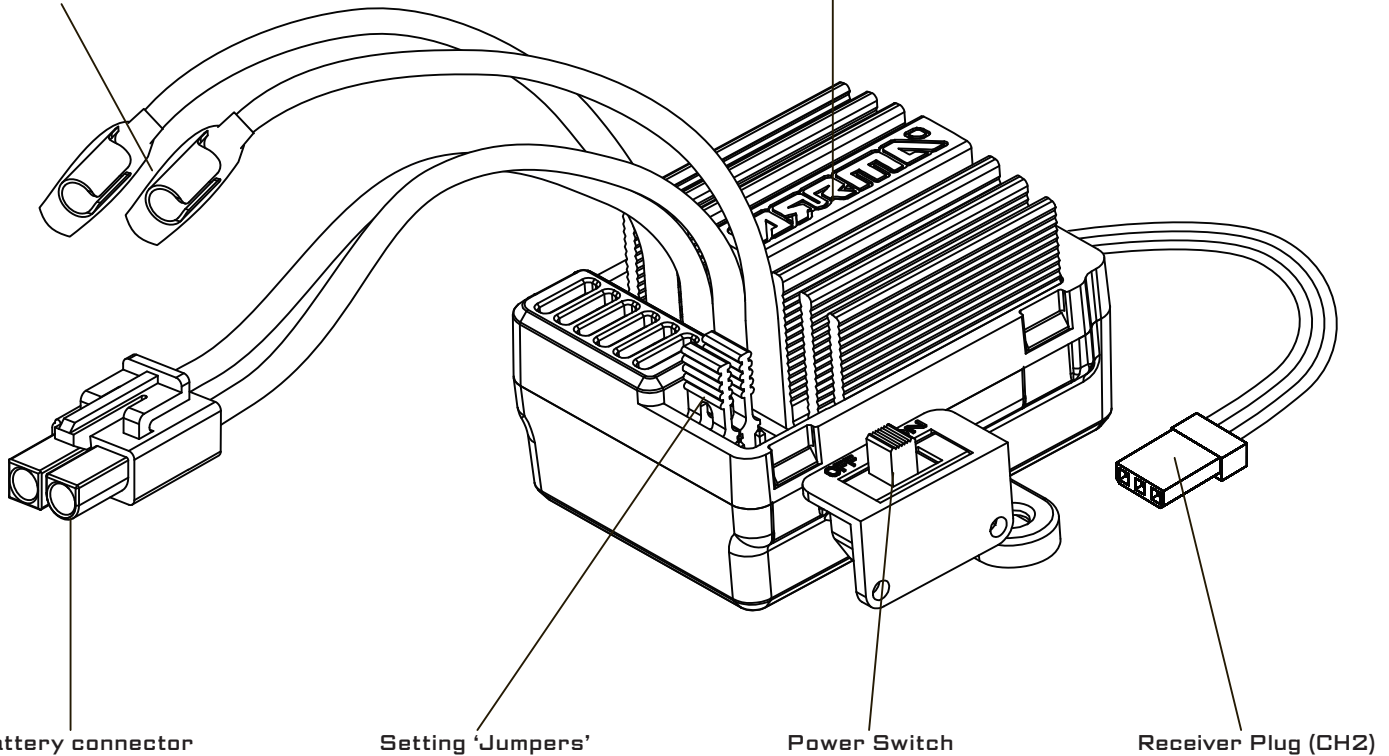

Battery connector

Setting 'Jumpers'

Power Switch

Receiver Plug (CH2)



HEAT-SINK MAY BE HOT AFTER USE

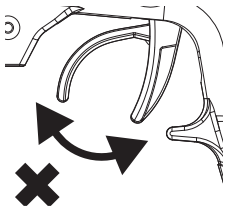

THROTTLE SETUP

Do not move the throttle when switching the model on and the ESC will automatically set the throttle neutral. A long beep will sound to confirm setup.

ESC STATUS LED

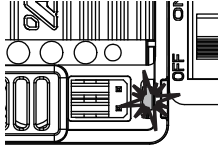

LED off: Neutral Throttle
 LED blinking slowly: Partial Forward/Reverse/Brake
 LED solidly on: Full Forward/Reverse/Brake



TEMPERATURE PROTECTION

If the ESC temperature exceeds 80 degrees Celsius for 5 seconds or longer, the ESC will enter temperature protection mode and the status LED will blink quickly. Once the ESC has cooled down it will resume normal operation.

LOW VOLTAGE CUT OFF

Battery Mode	NiMh	LiPo
Cut-off Voltage	4.5v	6.2v

FACTORY DEFAULTS

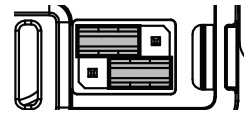

Battery Mode: NiMh
 Reverse: On

ESC TUNING

The MEGA brushed ESC has two tuning options - battery mode and reverse lock out. The setting of these modes can be changed by moving the position of the setting 'jumpers'.

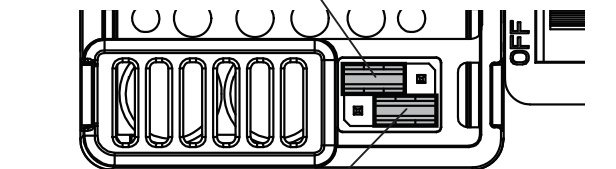
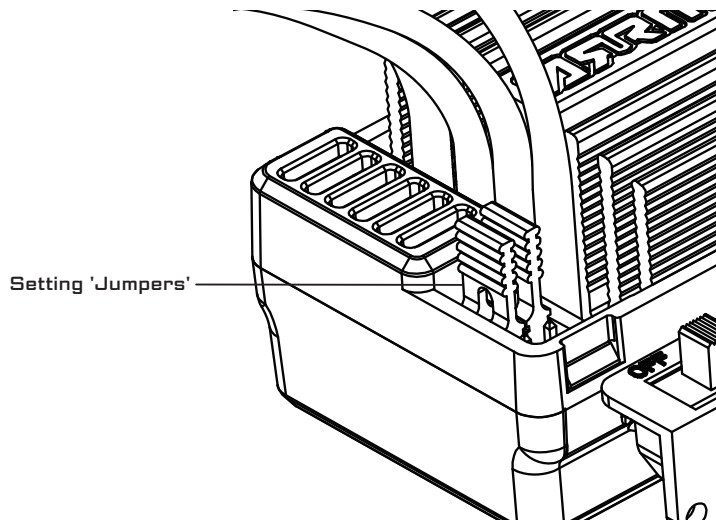



Battery Fitting

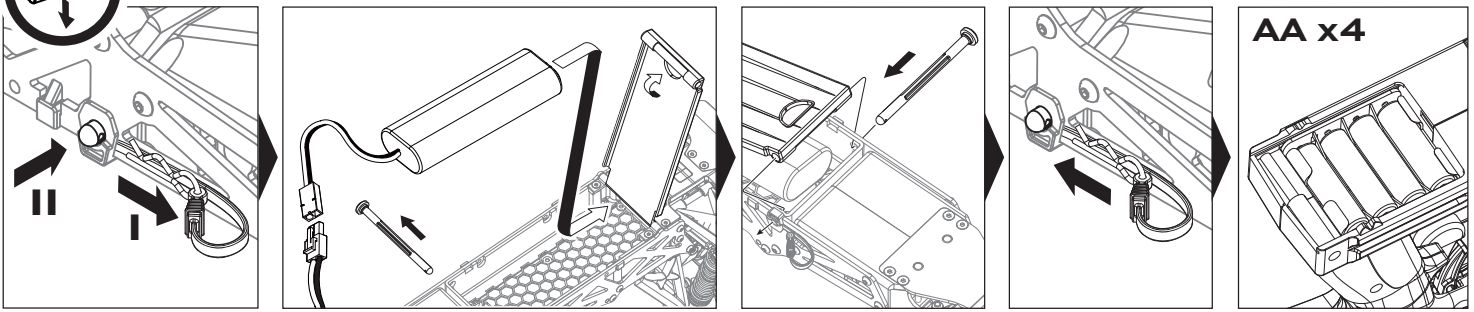

Running

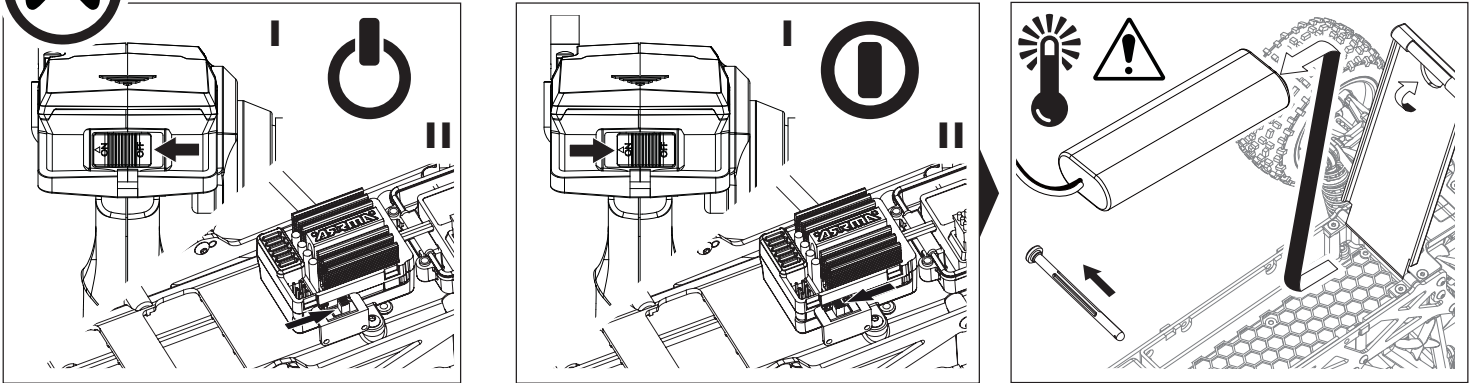

Driving Fundamentals

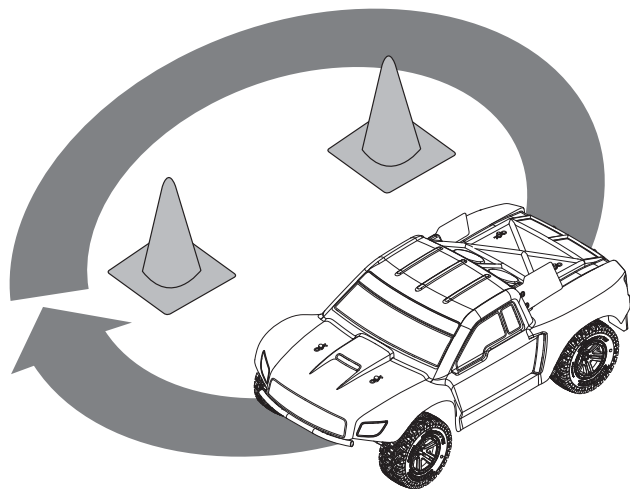

We design all ARRMA cars to be fun and quick to get used to. However, it is important to be comfortable with the handling before exploring the upper reaches of your car's performance.

For the first run we recommend taking your kit to an open, flat area (such as a park) ensuring you are away from potential hazards, people or animals.

Start by simply driving round in a large loop, slowly building up speed to get used to the handling. Alter the size of the loop and your speed. Watch out for the rear-end of the car breaking loose. If the car does slide try to counter-steer into the skid and accelerate out or let-off the throttle and let it come to a stop.

To take a corner you need to slow down before the corner, hold your speed through the curve and, once you see an exit line, accelerate out of the corner.

Once you have practiced the basic driving techniques and you are comfortable with the performance of the car you can start to open-up the full performance potential of your car.





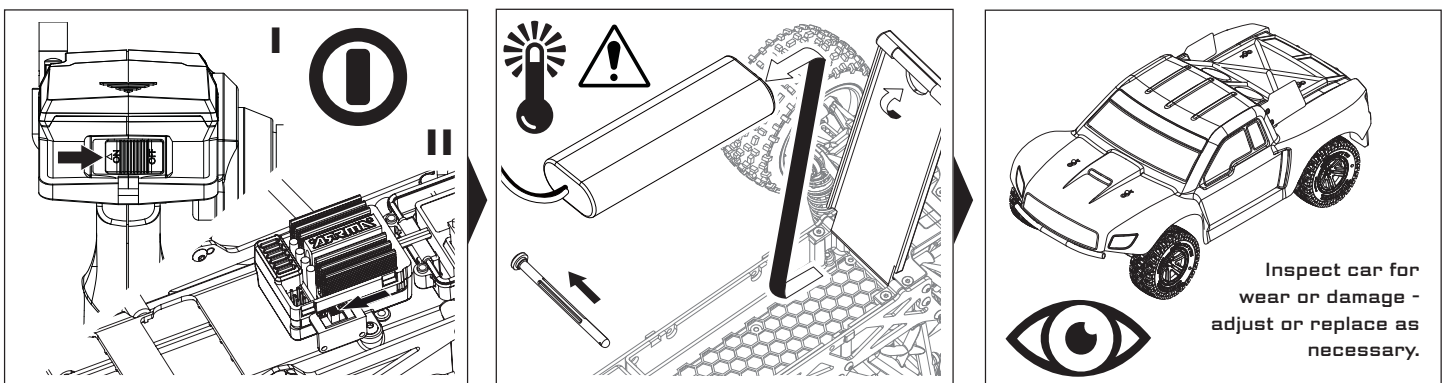



Post-Drive Checks



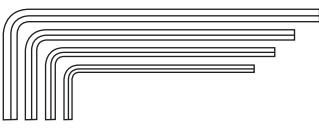
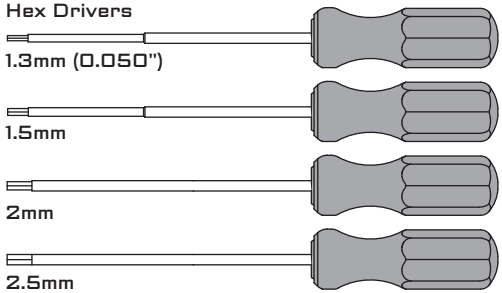
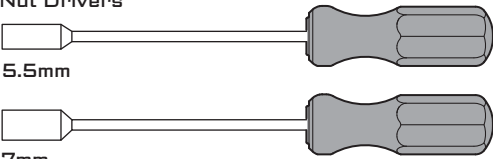
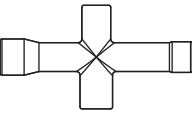
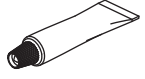

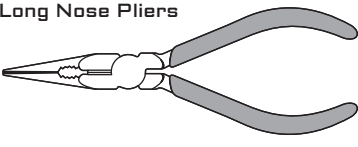
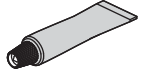
Maintenance

Recommended Tools

SUPPLIED	NOT SUPPLIED	
<p>Allen Keys</p>  <p>1.3 (0.050"), 1.5, 2, 2.5mm</p>	<p>Hex Drivers</p>  <p>1.3mm (0.050") 1.5mm 2mm 2.5mm</p>	<p>Nut Drivers</p>  <p>5.5mm 7mm</p>
<p>Cross wrench</p> 	<p>Grease</p> 	<p>Turnbuckle Wrench</p>  <p>4mm</p>
<p>Long Nose Pliers</p> 	<p>Thread-lock</p> 	<div style="border: 1px dashed black; padding: 5px;"> <p>HAZARDOUS/FLAMMABLE: Adult supervision required, use only in a well ventilated area and away from sources of ignition.</p>  </div>
	<p>Cloth</p>  <p>Brush</p>  <p>Oil Spray</p> 	



Basic Trouble Shooting - need help? Visit the support area and forums at ARRMA-RC.COM

Trouble Shooting Matrix

Problem	Possible Cause	Solution
VEHICLE DOES NOT MOVE	Batteries are incorrectly installed in transmitter	Check transmitter batteries and refit.
	Weak, damaged or no drive battery in model	Install fresh, charged battery
	Frayed or broken motor or electronic speed control (ESC) wires	Check condition, reconnect and insulate. Visit the GO FOR IT! forum for advice
	Electronic speed control (ESC) has shut down due to overheating	Stop driving and allow electronic speed control (ESC) or motor to cool down
	Electric motor is damaged	Replace with new unit - visit ARRMA-RC.com for advice and upgrades!
	Electronic speed control (ESC) is damaged	Replace with new unit - visit ARRMA-RC.com for advice and upgrades!
	Possible damage to transmission/drive-line	Check components and replace - visit ARRMA-RC.com for advice
	Electronic speed control (ESC) low voltage cutoff has activated.	Remove drive battery, leave to cool down if necessary, and re-charge
VEHICLE DOES NOT REVERSE	Electronic speed control (ESC) reverse mode switched off	Adjust reverse on electronic speed control (ESC)
	Electronic speed control (ESC) is damaged	Replace with new unit - visit ARRMA-RC.com for advice and upgrades!
VEHICLE DRIVES WITHOUT INPUT	Transmitter throttle trim incorrectly set	Throttle trim needs to be set to zero/neutral.
	Neutral throttle position of Electronic Speed Control (ESC) incorrect.	Set throttle trim to zero and switch electronic speed control (ESC) off and then on again, a chime to indicate the new neutral position has been set
SHORT RUNTIME	Battery damaged or not fully charged	Check condition, replace or recharge
	Electric motor dirty or damaged	Clean, check condition and/or replace - visit ARRMA-RC.com for more information
	Incorrect electronic speed control (ESC) battery mode.	Adjust the battery mode of the electronic speed control (ESC)
SLUGGISH PERFORMANCE	Battery damaged or not fully charged	Check condition, replace or recharge
	Transmitter throttle trim incorrectly set	Throttle trim needs to be set to zero/neutral.

Trouble Shooting Matrix (cont.)

Problem	Possible Cause	Solution
	Neutral throttle position of electronic speed control (ESC) incorrect.	Set throttle trim to zero and switch electronic speed control (ESC) off and then on again, a chime to indicate the new neutral position has been set
SLUGGISH PERFORMANCE (CONTINUED)	Slipper clutch adjustment too loose	Check slipper is set to factory setting or your preferred setting.
	Electric motor dirty or damaged	Clean, check condition and/or replace - visit ARRMA-RC.com for more information
	Drivetrain dirty or damaged	Clean, check condition and/or replace - visit ARRMA-RC.com for more information
FRONT WHEELS LIFT WHEN ACCELERATING	Slipper clutch adjustment too tight	Check slipper is set to factory setting.
NO CONTROL OF VEHICLE OR SHORT RANGE	Transmitter batteries are weak or fitted incorrectly	Check transmitter batteries and refit.
	Servo and ESC signal wires to receiver loose or connected incorrectly	Reinstall signal wires to receiver
	Transmitter and receiver are not 'bound' correctly	Transmitter and receiver need to be bound.
STEERING/THROTTLE OPERATION INTERMITTENT	Electronic speed control (ESC) has shut down due to overheating	Stop driving and allow electronic speed control (ESC) or motor to cool down
	Transmitter and receiver are not bound fully or are suffering interference	Check for sources of interference and re-bind transmitter/receiver.
VEHICLE WANDERS LEFT/RIGHT WITHOUT STEERING INPUT	Transmitter steering trim setting out	Adjust steering trim on transmitter.
	Damaged steering components	Check components and replace - visit ARRMA-RC.com for advice
	Drivetrain dirty or damaged	Clean, check condition and/or replace - visit ARRMA-RC.com for more information
STEERING OR THROTTLE FUNCTION REVERSED	Relevant channel on transmitter is reversed	Reverse relevant channel on transmitter.
	Check that the wires from the electronic speed controller (ESC) to the motor are connected correctly	Reconnect in the correct orientation, ensuring fit is tight; if not pinch female connector with pliers
LIMITED STEERING ANGLE	Transmitter steering dual-rate set incorrectly	Adjust transmitter dual-rate.
	Damaged steering components	Check components and replace - visit ARRMA-RC.com for advice
	Electronic speed control (ESC) is damaged	Replace with new unit - visit ARRMA-RC.com for advice and upgrades!

Maintenance Schedule

This chart is just a guide. Running in dusty, sandy or wet conditions will mean certain maintenance tasks will need to be performed more frequently. Check for wear or damage after every run. Do not wait until the recommended time for maintenance if parts appear badly worn or need renewing.

 MAINTENANCE TASK	PAGE	RUNS	X1	X10	X20	X50
Chassis Maintenance	12					
Wheel and Tyre Maintenance	12					
Slipper clutch Adjustment	13					
Spur/Pinion Mesh Adjustment	13					
Slipper Pad Replacement	14					
Driveshaft Maintenance	15					
Rear Axle Maintenance	15					
Wheel Bearing Replacement	16					
Shock Oil Replacement	20					
Differential Oil Replacement	22					

Chassis Maintenance

ONLINE VIDEOS WHEN YOU SEE THIS ICON >>



Tools Required



AFTER RUNNING:

- Ensure that drivetrain, suspension and steering are clean, free and lubricated
- Check that all the screws are tight
- Check tyre/wheel condition

DO NOT RUN THE CAR IF ANY PARTS ARE DAMAGED

Please contact your local distributor to order replacement parts.

N.B. Raider chassis shown as an example - information applies to all variants.

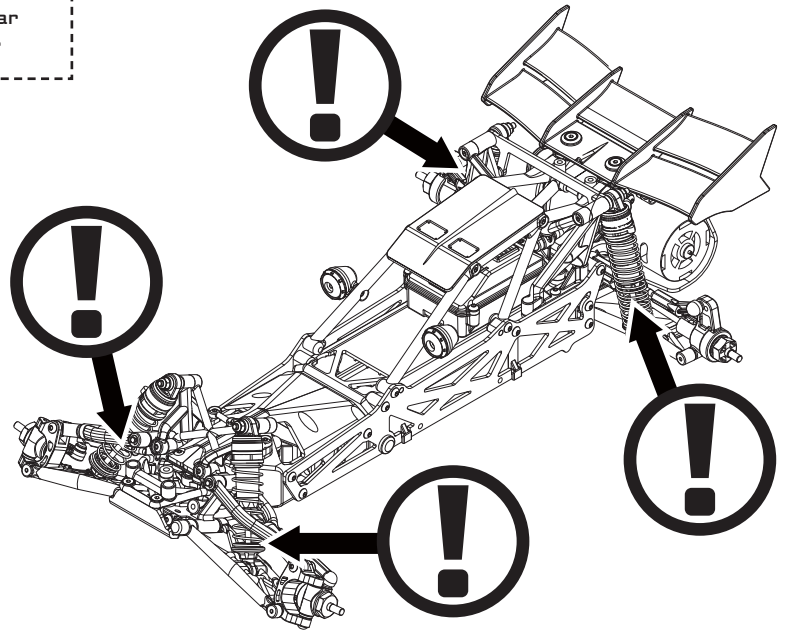

Wheel and Tyre Maintenance

N.B. Fury shown as an example - information applies to all variants.



Tools Required

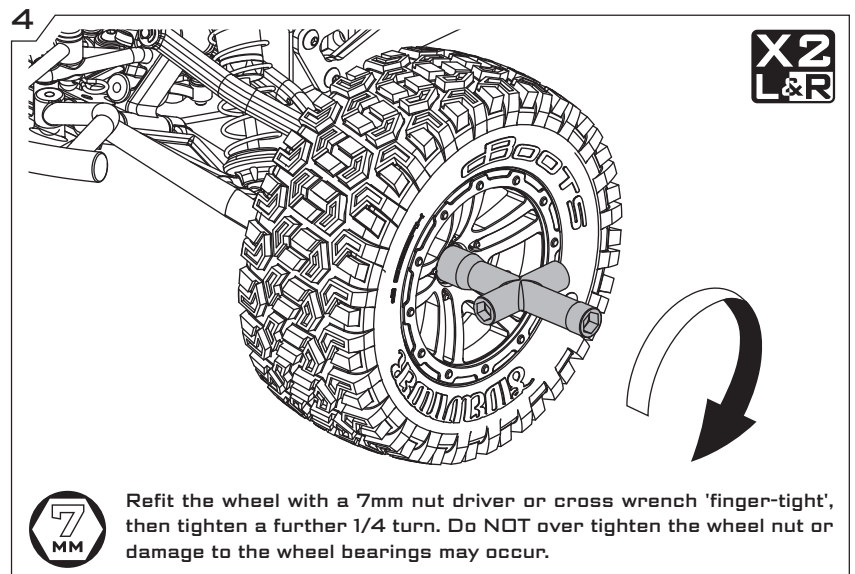
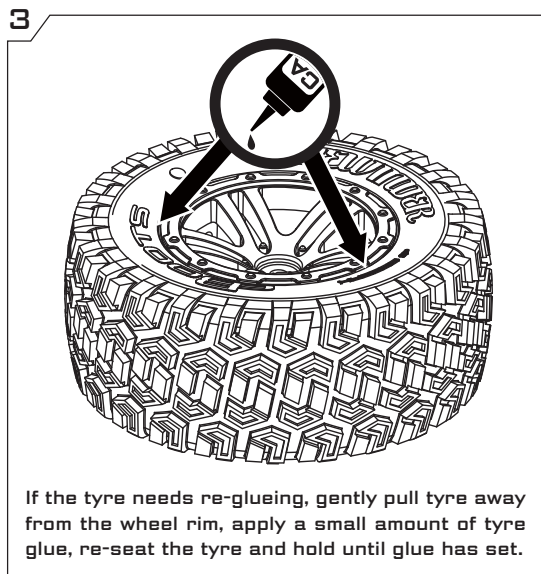
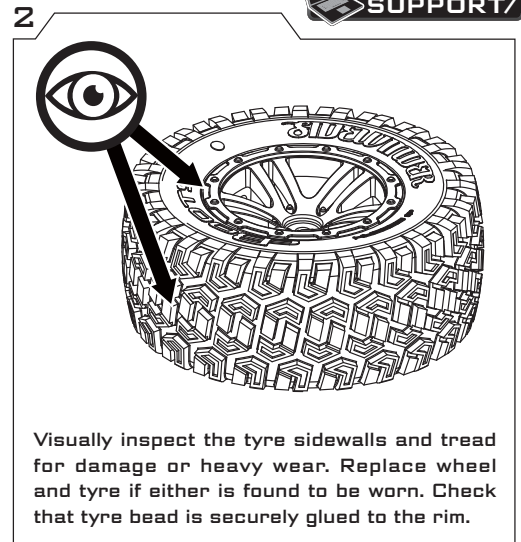
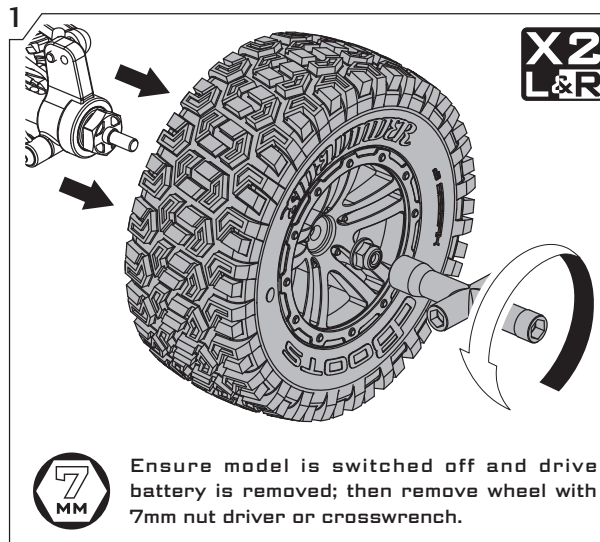
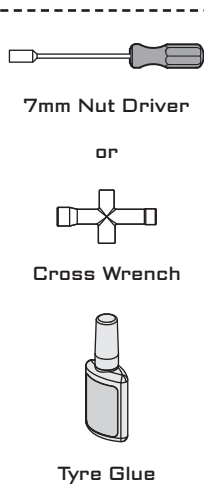

Slipper Clutch Adjustment



The function of the slipper clutch is to protect the gearbox, differential and motor from shocks and also to allow you to tune how the torque from the motor 'comes-in' when you accelerate to suit different surface conditions. To adjust the slipper clutch do the following:

Tools Required

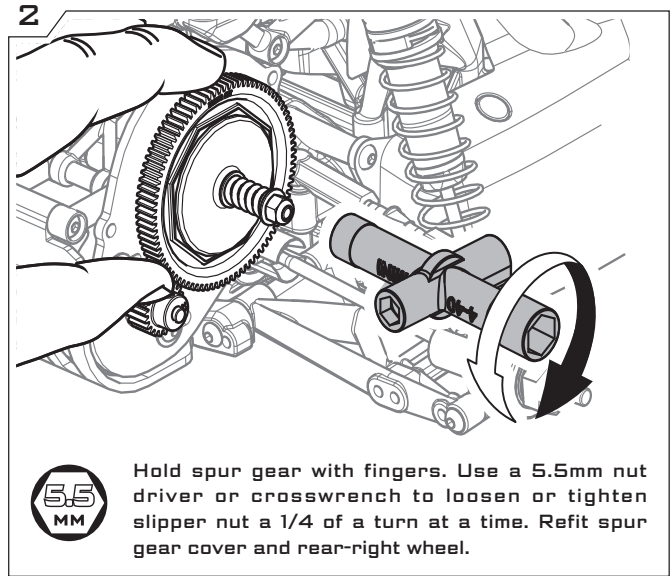
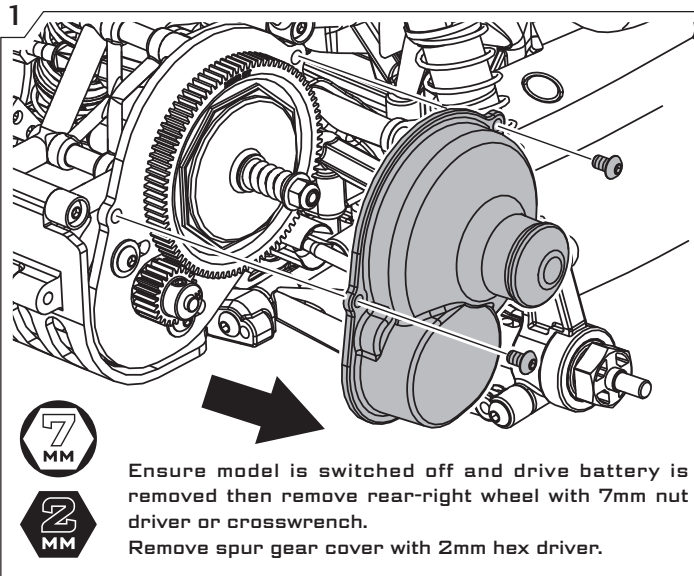
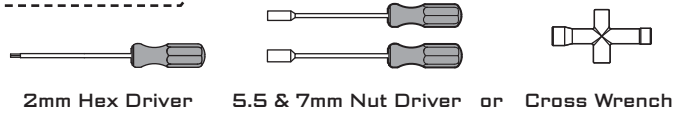

Surface Type	Slipper Clutch	Characteristics
Slippery	Loosen	Smoother power delivery, easier to control.
High Grip	Tighten	Quicker throttle response. If the car wheelies too much, loosen the Slipper Clutch

Factory Setting
1. Fully tighten locknut clockwise.
2. Loosen 4.5 turns.

AFTER RUNNING:

If slipper clutch is too loose, tighten 1/4 turn.



WARNING: A loose slipper will damage the friction pads. If the slipper is too tight it may damage the transmission.

Spur/Pinion Mesh Adjustment



Gear mesh should not need to be adjusted regularly, however it is worth checking every 10 runs or so that the gears are still correctly meshed to prevent damage to the spur gear.

Tools Required

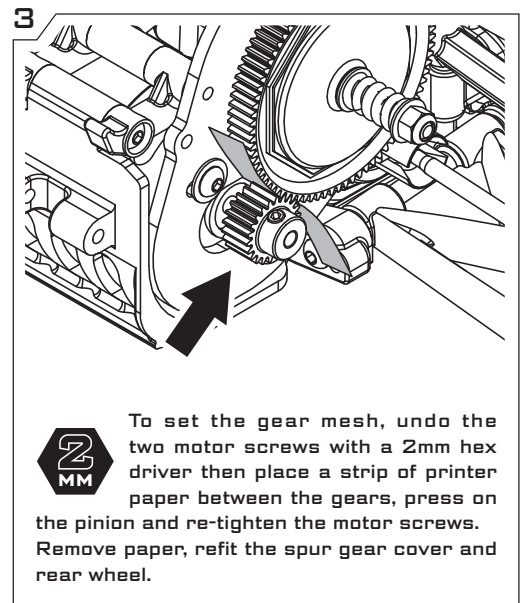
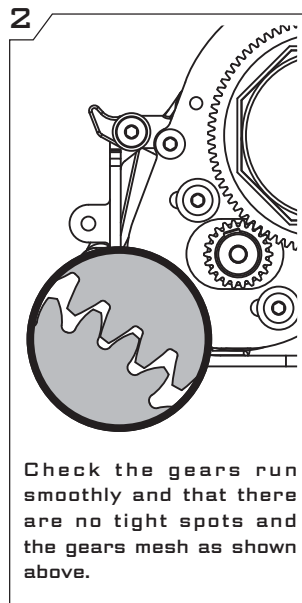
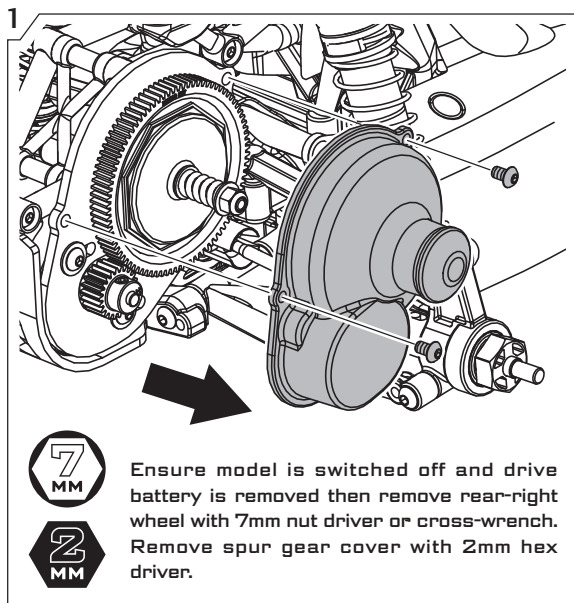
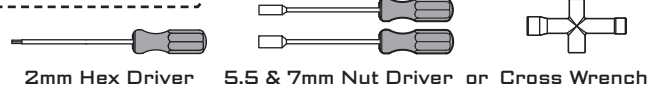

If the spur and/or pinion gear need to be replaced please see page 21 for removal and replacement.

Slipper Pad Replacement



Every 20 runs or so it may be necessary to replace your slipper clutch 'pads'. This depends on how the slipper is setup and your driving style. If you find that it is hard to get the setting you want from your slipper clutch then it is likely that the pads need to be replaced.

Tools Required

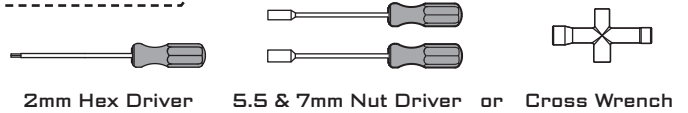

1

7 MM
2 MM

Ensure model is switched off and drive battery is removed then remove rear-right wheel with 7mm nut driver or cross-wrench. Remove spur gear cover with 2mm hex driver.

2

5.5 MM

Hold the spur gear with your fingers. Use a 5.5mm nut driver or cross-wrench to remove the slipper clutch adjustment nut.

3

7 MM

Slipper Pads
PN:
310018

Remove the slipper clutch adjustment mechanism, slipper plates and spur gear. Remove old slipper pads from spur gear and discard.

4

Affix the new slipper pads to the spur gear.

5

5.5 MM

Refit the slipper clutch & adjustment mechanism. Tighten the adjustment nut fully.

6

5.5 MM **2 MM** **7 MM**

Loosen the adjustment nut 4.5 turns. Refit spur gear cover and rear wheel.

Driveshaft Maintenance



Every 20 runs or so it may be necessary to clean and re-grease the drive-shafts as well as check for wear and/or damage. Running in dusty, sandy or wet conditions will mean that this will need to be performed more frequently.

Tools Required

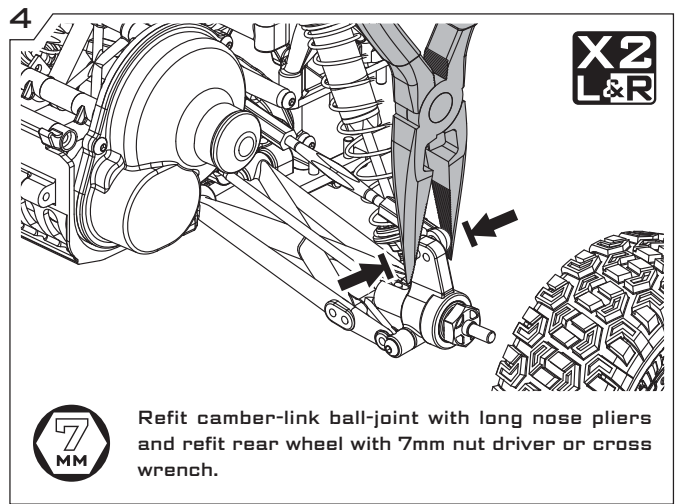
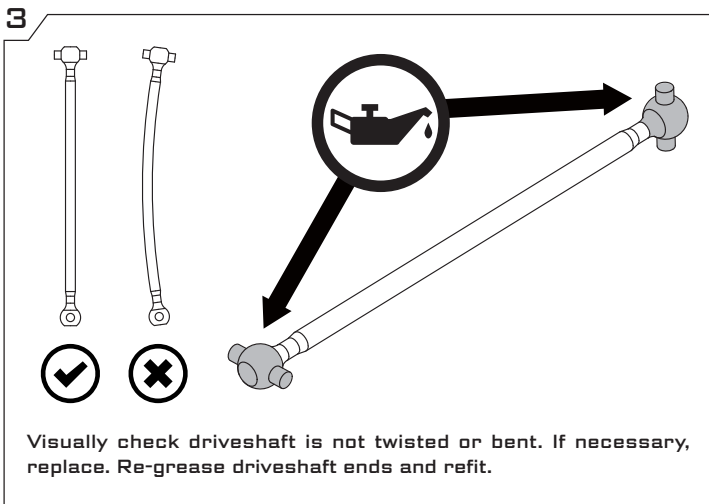
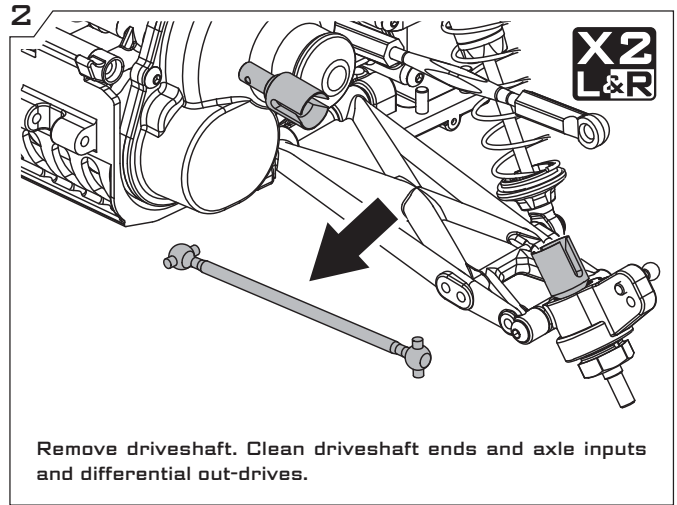
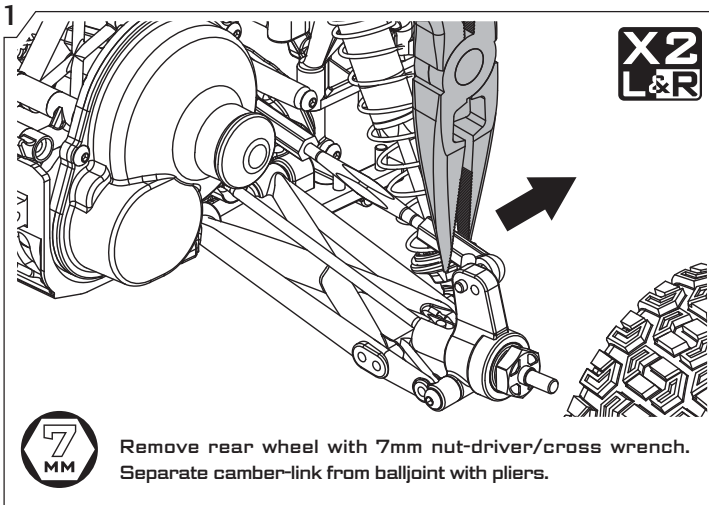

Rear Axle Maintenance



Every 20 runs or so it may be necessary to inspect the rear axle for wear. Running the model in dusty, sandy or wet conditions will mean that this will need to be performed more frequently.

Tools Required

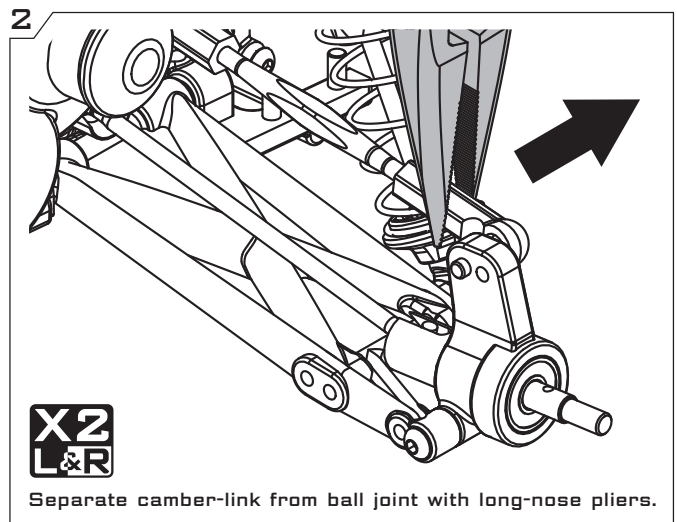
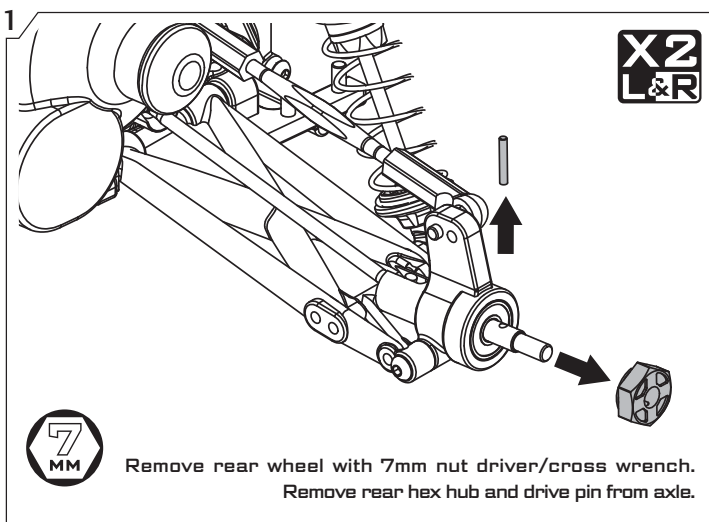
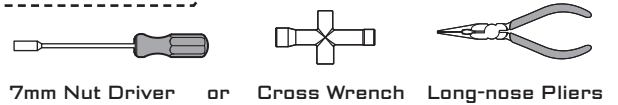

Rear Axle Maintenance (cont.)

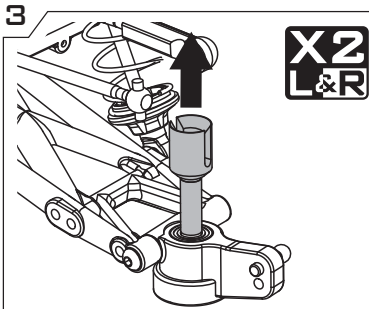

Rotate rear hub carrier to allow better access and push axle up through bearings.

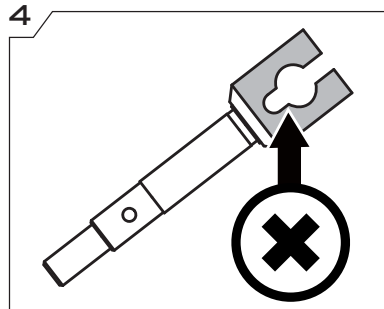

Clean and check condition of rear axle. If worn as shown above, replace axle.

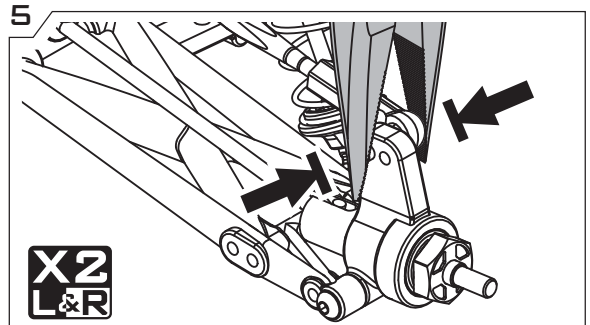

X2
L&R

7
MM

Refit driveshaft, camber-link, drive pin, rear hex hub and rear wheel.

Wheel Bearing Replacement



Every 50 runs or so it may be necessary to inspect the wheel bearings for wear. Running the model in dusty, sandy or wet conditions will mean that this will need to be performed more frequently.

Tools Required



7mm Nut Driver or Cross Wrench Long-nose Pliers

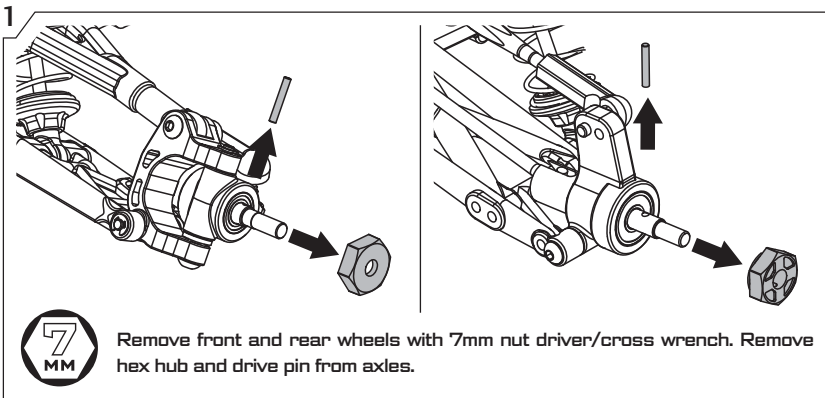

7
MM

Remove front and rear wheels with 7mm nut driver/cross wrench. Remove hex hub and drive pin from axles.

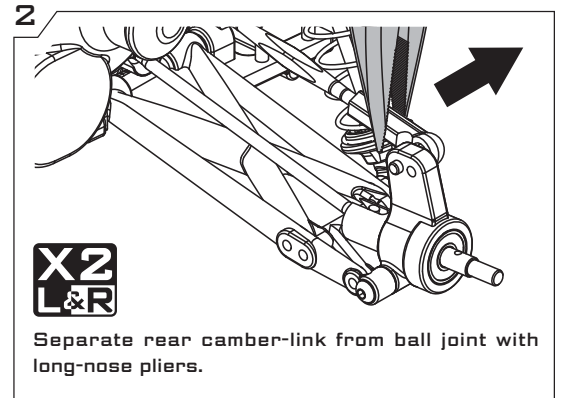

X2
L&R

Separate rear camber-link from ball joint with long-nose pliers.

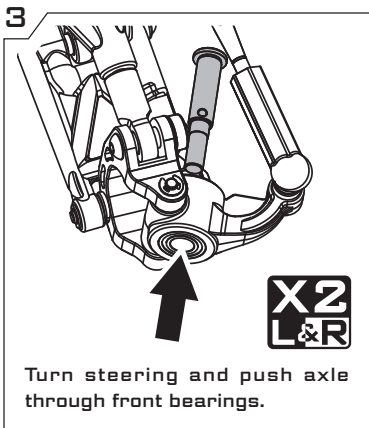

X2
L&R

Turn steering and push axle through front bearings.

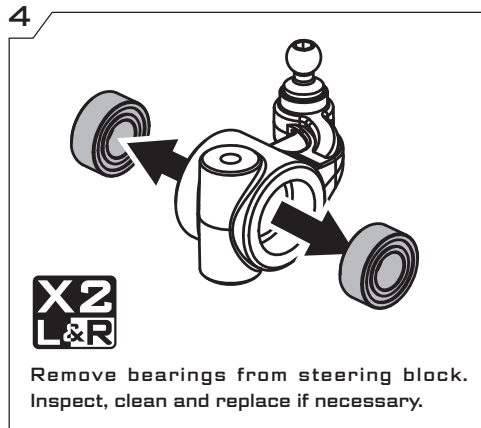

X2
L&R

Remove bearings from steering block. Inspect, clean and replace if necessary.

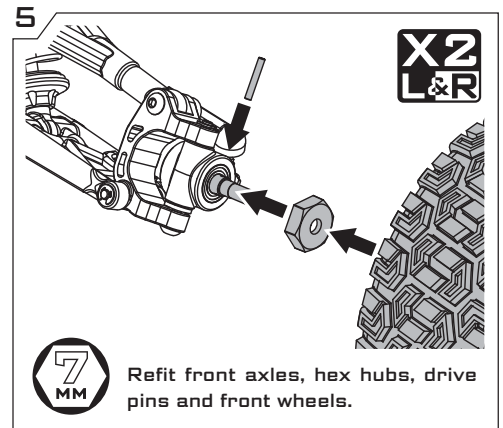

X2
L&R

7
MM

Refit front axles, hex hubs, drive pins and front wheels.

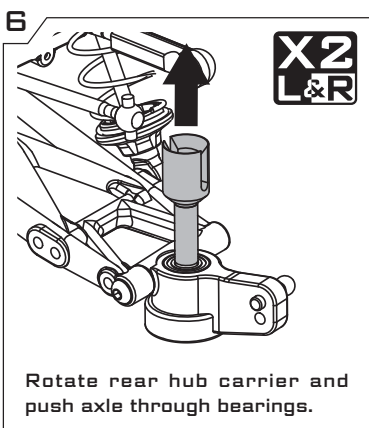

X2
L&R

Rotate rear hub carrier and push axle through bearings.

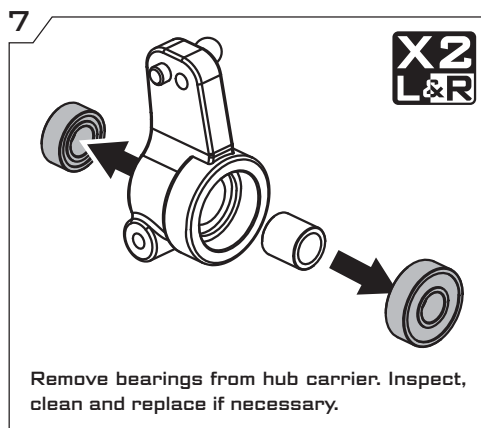

X2
L&R

Remove bearings from hub carrier. Inspect, clean and replace if necessary.

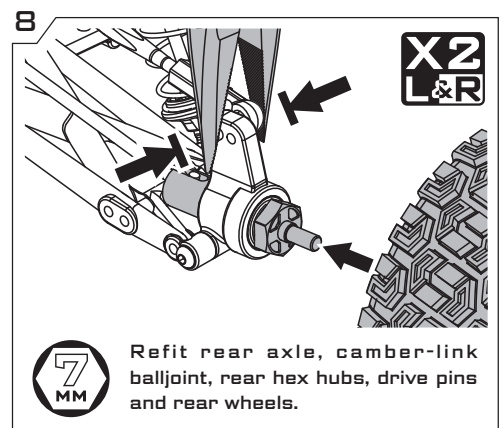

X2
L&R

7
MM

Refit rear axle, camber-link balljoint, rear hex hubs, drive pins and rear wheels.



ARRMA

Factory Settings

Front

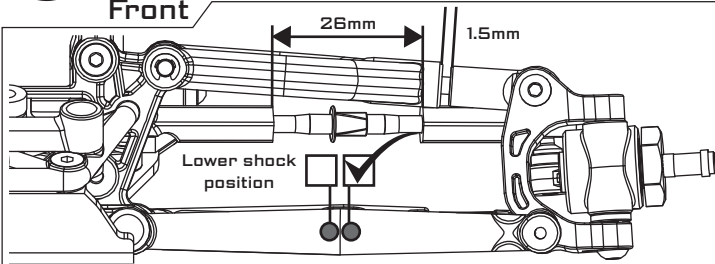

Ride Height
27.5 mm

Camber
-1.0 °

Toe Angle
0 (Zero) °

Shocks

	FRONT	REAR
Piston	2 x 1.3mm	2 x 1.3mm
Oil wt.	350 cst	350 cst
Spring	45mm 63.5gf/mm	70mm 40gf/mm

Rear

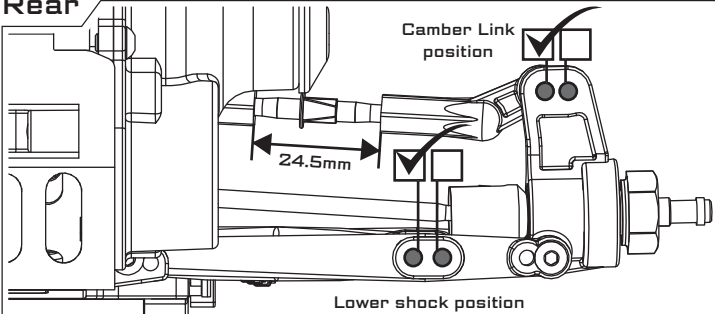

Ride Height
28 mm

Camber
-0 °

Differential

Oil wt.	3000 cst
---------	-----------------

Motor/Gears

Motor MEGA 15T	Spur Gear 81T 48dp
ESC MEGA	Pinion Gear 22t 48dp

ADX10

Factory Settings

Front

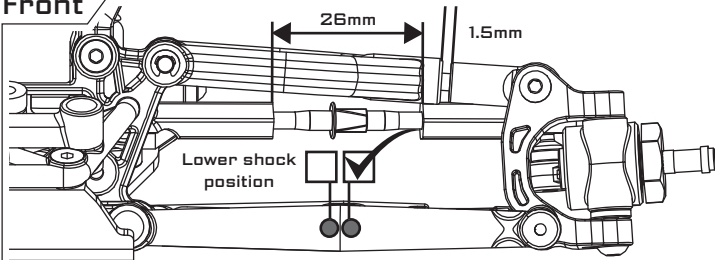

Ride Height
27.5 mm

Camber
-1.0 °

Toe Angle
0 (Zero) °

Shocks

	FRONT	REAR
Piston	2 x 1.3mm	2 x 1.3mm
Oil wt.	350 cst	350 cst
Spring	45mm 63.5gf/mm	70mm 40gf/mm

Rear

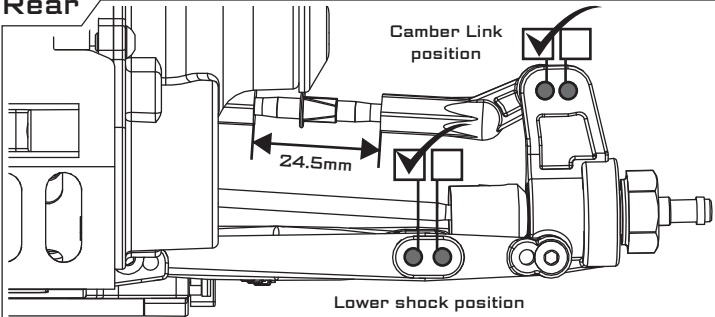

Ride Height
28 mm

Camber
-0 °

Differential

Oil wt.	3000 cst
---------	-----------------

Motor/Gears

Motor MEGA 15T	Spur Gear 81T 48dp
ESC MEGA	Pinion Gear 22t 48dp

FURY

Factory Settings

Front

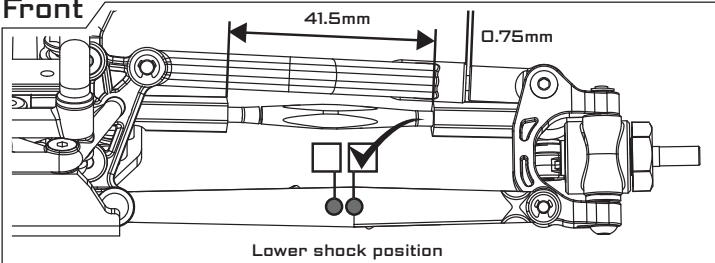

Ride Height
38.5 mm

Camber
-1.0 °

Toe Angle
0 (Zero) °

Shocks

	FRONT	REAR
Piston	2 x 1.3mm	2 x 1.3mm
Oil wt.	350 cst	350 cst
Spring	50mm 73.5gf/mm	72mm 47gf/mm

Rear

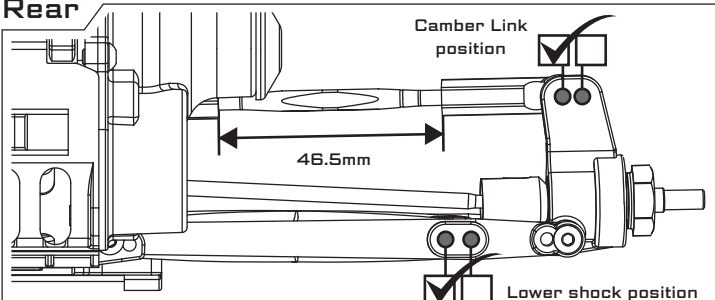

Ride Height
39 mm

Camber
-0 °

Differential

Oil wt.	3000 cst
---------	-----------------

Motor/Gears

Motor MEGA 15T	Spur Gear 87t 48dp
ESC MEGA	Pinion Gear 18t 48dp

MOJAVE Factory Settings

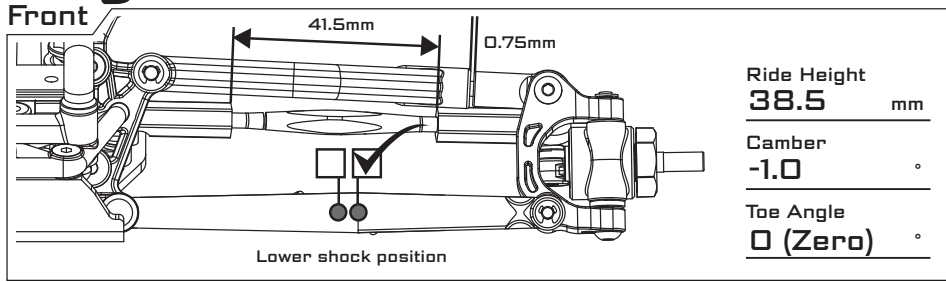

Ride Height
38.5 mm

Camber
-1.0 °

Toe Angle
0 (Zero) °

	FRONT	REAR
Piston	2 x 1.3mm	2 x 1.3mm
Oil wt.	350 cst	350 cst
Spring	50mm 73.5gf/mm	72mm 47gf/mm

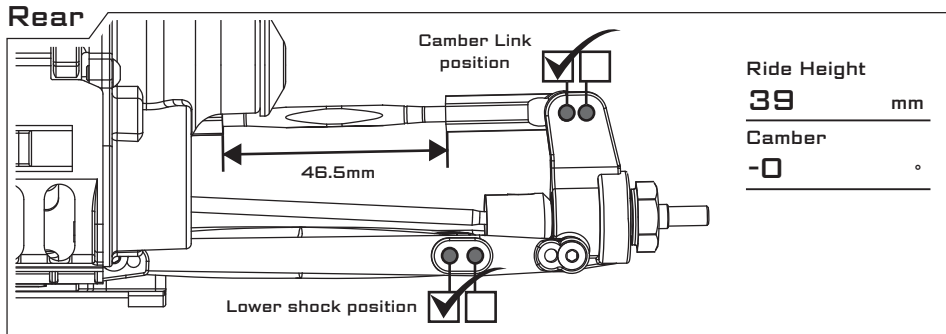

Ride Height
39 mm

Camber
-0 °

Differential	
Oil wt.	3000 cst

Motor/Gears	
Motor	Spur Gear
MEGA 15T	87t 48dp
ESC	Pinion Gear
MEGA	18t 48dp

VORTEX Factory Settings

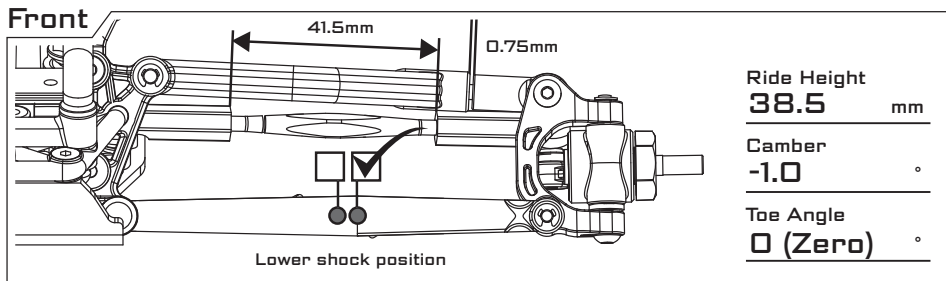

Ride Height
38.5 mm

Camber
-1.0 °

Toe Angle
0 (Zero) °

	FRONT	REAR
Piston	2 x 1.3mm	2 x 1.3mm
Oil wt.	350 cst	350 cst
Spring	50mm 73.5gf/mm	72mm 47gf/mm

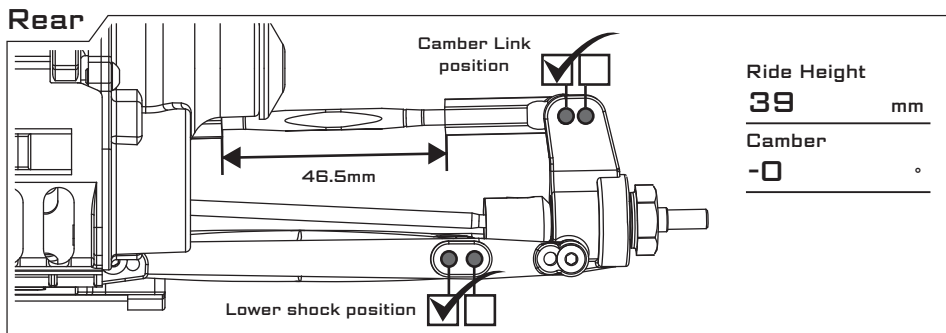

Ride Height
39 mm

Camber
-0 °

Differential	
Oil wt.	3000 cst

Motor/Gears	
Motor	Spur Gear
MEGA 15T	87t 48dp
ESC	Pinion Gear
MEGA	18t 48dp

GRANITE Factory Settings

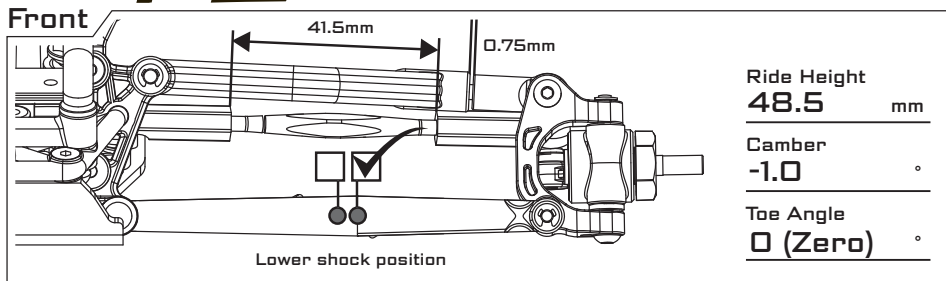

Ride Height
48.5 mm

Camber
-1.0 °

Toe Angle
0 (Zero) °

	FRONT	REAR
Piston	2 x 1.3mm	2 x 1.3mm
Oil wt.	350 cst	350 cst
Spring	50mm 73.5gf/mm	72mm 47gf/mm

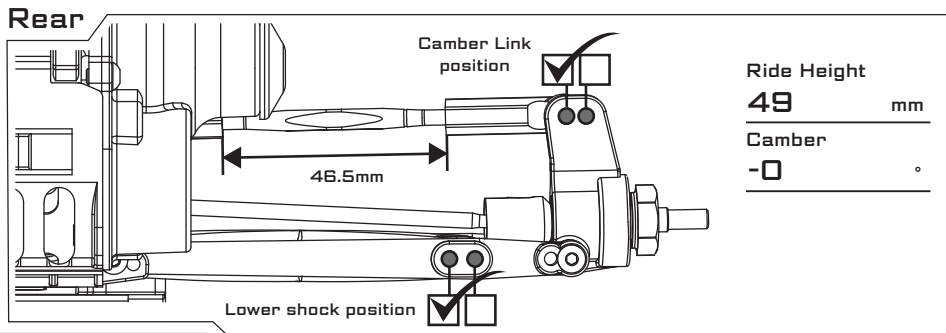

Ride Height
49 mm

Camber
-0 °

Differential	
Oil wt.	3000 cst

Motor/Gears	
Motor	Spur Gear
MEGA 15T	87t 48dp
ESC	Pinion Gear
MEGA	15t 48dp



N.B. Raider shown as an example - information applies to all variants.

Ride Height

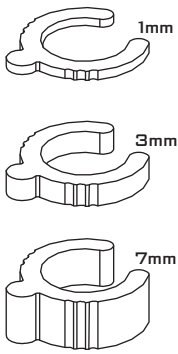

The ride height is set using preload spacers between the top of the shock and the top of the suspension springs. These plastic clips are included in the kit in 1mm, 3mm and 7mm versions.

Raising the ride height not only gives you greater ground clearance when running on more uneven surfaces but it can also affect the chassis balance of the car. Experiment by raising the height of the front and rear at the same time or independently and see how it affects the handling of your car.

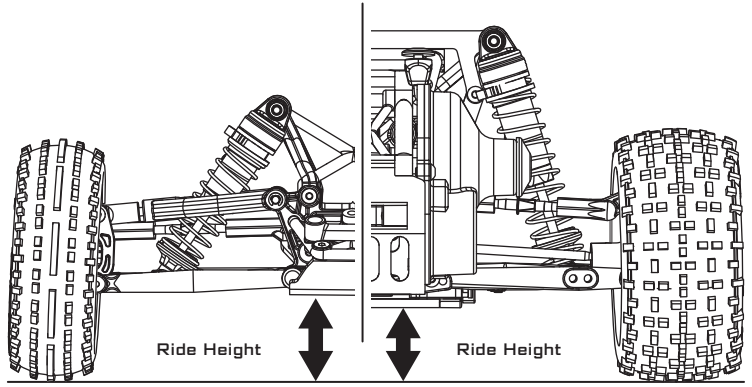

Camber Link Length

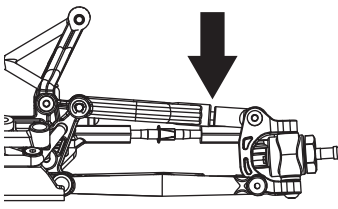
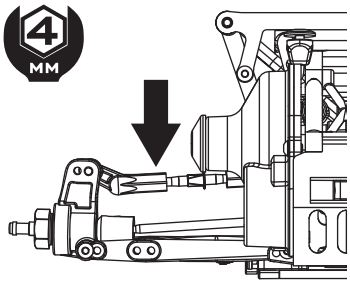

The camber links are the arms that link the top of hubs to the chassis. The length can be adjusted to alter the camber of the front and rear wheels. The adjustments and their effects are listed below:

	LENGTH	CHARACTERISTIC
Front	Shorter	More negative camber, more stability, smoother steering, slower response.
	Longer	Less negative camber, more direct steering, quicker response.
Rear	Shorter	More negative camber, less forward traction, smoother cornering, use for high grip surfaces.
	Longer	Less negative camber, more forward traction, less smooth cornering, good for low grip surfaces.

Steering Arm Length (Toe-In/Out)

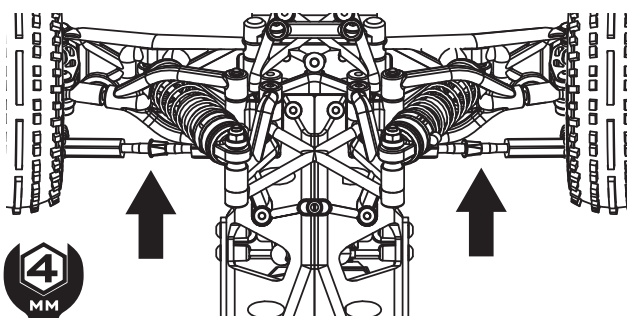

The steering arm links are the connection between the front hubs and the steering mechanism in the chassis. The length of these can adjust the front toe-in/-out.

Adjusting the toe can create either toe-in, which is where the wheels point inwards towards a centreline in front of the vehicle, or toe-out where the wheels point towards a centreline behind the vehicle. The effect of these adjustments is below:

LENGTH	CHARACTERISTIC
Standard	Zero toe, standard setting, neutral handling.
Shorter	Toe-Out, increasing cornering ability, less stability on straights.
Longer	Toe-In, more stability on straights.

Camber Link Position

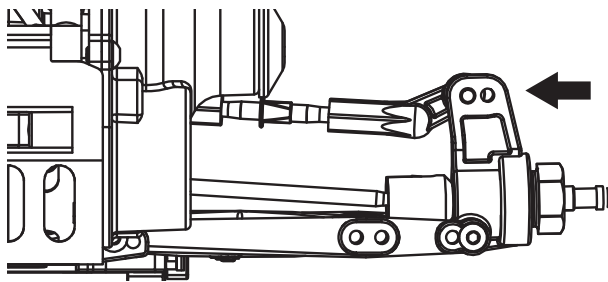

The camber links are the arms that link the top of hubs to the chassis. The length can be adjusted to alter the camber of the front and rear wheels.

The adjustments and their effects are listed below:

POSITION	CHARACTERISTIC
Inner	Standard position, Less chassis roll, lower overall grip, quicker to respond to inputs.
Outer	(Adjust camber link turbuckle to return camber to correct angle) More chassis roll, more overall grip, slower to respond to inputs.

Shock Position

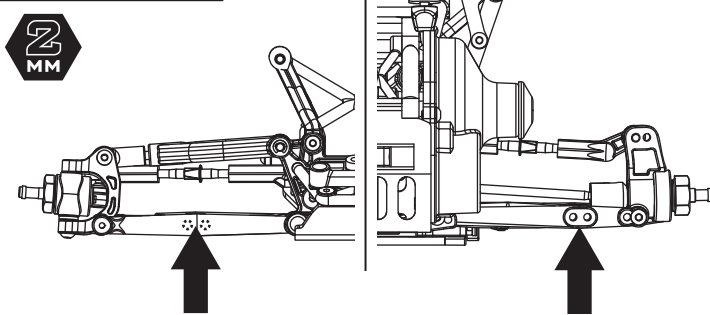

The shock mounting position is where the bottom of the shock mounts to the lower wishbone of the suspension.

Adjusting the angle of the shock can change the way the suspension reacts to bumps and also cornering forces.

The effect of these adjustments is below:

ANGLE	CHARACTERISTIC
Inner position	Softer damping, better over bumps, slower response, more overall grip.
Outer position	Stiffer damping, better on smooth surfaces, faster response, slightly less grip.

Shock Removal



Every 50 runs or so it may be necessary to change the shock oil because over time it will become thinner meaning kit handling could be affected. You can also use this as an opportunity to upgrade the springs or shock oil.

Tools Required

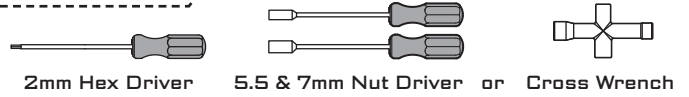

Front

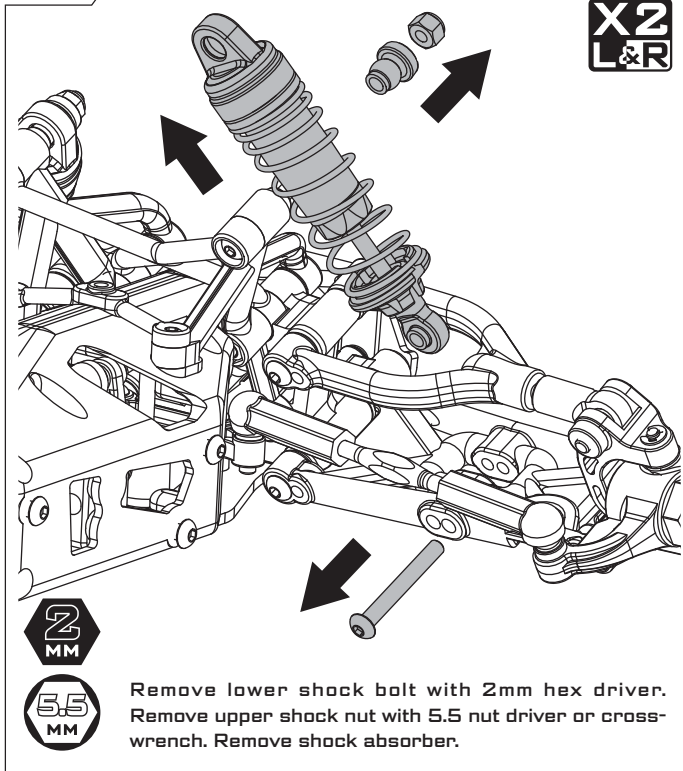

Remove lower shock bolt with 2mm hex driver. Remove upper shock nut with 5.5 nut driver or cross-wrench. Remove shock absorber.

Rear

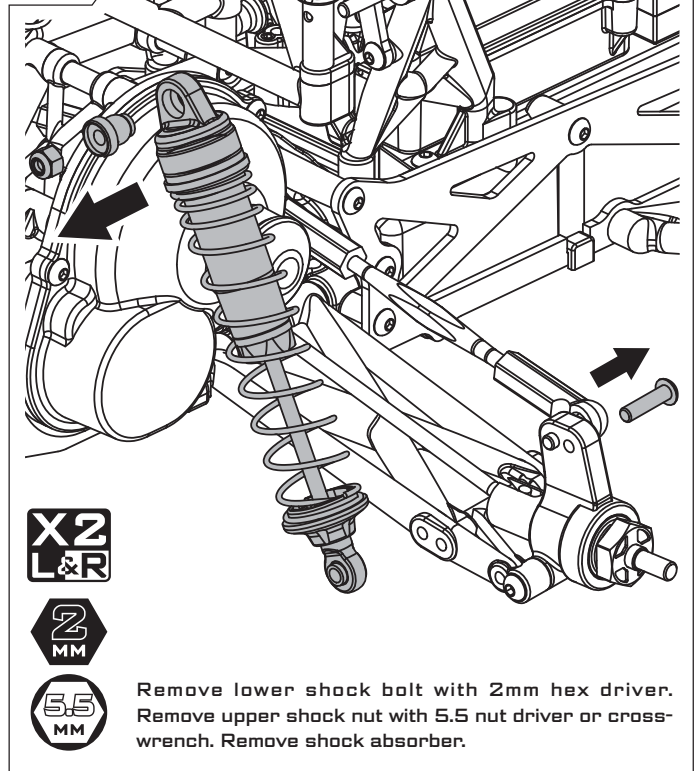

Remove lower shock bolt with 2mm hex driver. Remove upper shock nut with 5.5 nut driver or cross-wrench. Remove shock absorber.

Springs

Your kit's standard springs are quite soft to give the best compromise between handling and performance.

Swapping the springs for either softer or stiffer springs can alter the handling characteristic of the car significantly. To change the springs remove the lower spring support and slide the spring over the shock body.

To find out what spring options there are for your kit please visit ARRMA-RC.com or speak to your local distributor.

STRENGTH	CHARACTERISTIC
Softer	More traction
	More chassis roll
	More chance of 'bottoming out'
Stiffer	Better on bumpy surfaces
	Less traction
	Car quicker to react
	Less chassis roll
	Less chance of 'bottoming out'
	Better on smooth surfaces

Shock Oil

The standard shock oil in your kit's shocks is intended to provide forgiving, fun handling and allow the shocks to soak-up any punishment you choose to give them.

Changing the oil within the shock absorber can significantly change the handling and performance of the car.

WEIGHT	CHARACTERISTIC
Thinner	Softer damping
(lower CST)	More traction
	Quicker chassis weight transfer
	Car reacts more quickly
	More chassis roll
	More chance of 'bottoming out'
Heavier	Stiffer damping
(higher CST)	Slower chassis weight transfer
	Car slower to react
	Less chassis roll
	Less chance of 'bottoming out'

HOW TO CHANGE YOUR SHOCK OIL

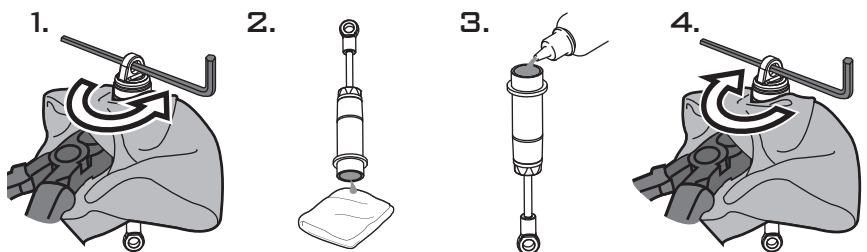

1. Hold the shock body carefully in a pair of pliers, place an allen key through the shock cap and turn anti-clockwise to loosen.

2. Remove the cap and turn the shock upside down over a cloth and push the piston to remove the shock oil. Leave to drain.

3. Stand the shock upright and extend the shaft fully. Fill the shock body to the top with the new oil and leave for a few minutes to settle.

4. Carefully screw the cap back onto the shock body and tighten clockwise until the seals compress. Clean up any excess oil.



Drivetrain Tuning

Gear Chart

Your ARRMA kit has one gear ratio and this can be altered by changing the pinion or spur gear in the transmission. The standard gearing of your kit is designed to give the best compromise between speed and acceleration. Increasing the top speed will reduce acceleration and vice versa. Too low or high a gear will put strain on the motor/ESC, and potentially damage them.



PINION GEAR (T-TOOTH)	13T	14T	15T	16T	17T	18T	19T	20T	21T	22T	23T	24T	25T	26T	27T	28T	29T	30T
SPUR GEAR	81T 48DP					4.5	4.26	4.05	3.86	3.68*1	3.52	3.38	3.24	3.12	3	2.89	2.79	2.7
	87T 48DP	6.69	6.21	5.8**3	5.44	5.12	4.83**2	4.58	4.35	4.14	3.95	3.78	3.63					

STANDARD GEAR RATIOS *1 = Raider/ADX-10 *2 = Fury/Mojave/Vorteks *3 = Granite

The numbers shown in chart is the number of times the spur gear is larger than the pinion, or the 'gear ratio'. Essentially this is number of rotations the motor/pinion gear has to rotate the larger spur gear once. The lower the 'gear ratio' the greater the potential top speed, the higher the 'gear ratio' the greater the potential acceleration.

Upgraded motors/ESCs and non-standard wheels may require different gear ratios. Try to find the best balance between speed/acceleration and handling/performance. For help selecting the correct gear ratio for your upgrades visit the GO FOR IT forums at GOFORIT-RC.com.

Spur/Pinion Gear Removal and Replacement



Tools Required

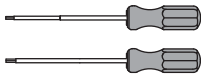

1.5 & 2mm Hex Drivers

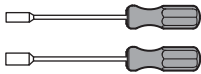

5.5 & 7mm Nut Driver

or



Cross Wrench

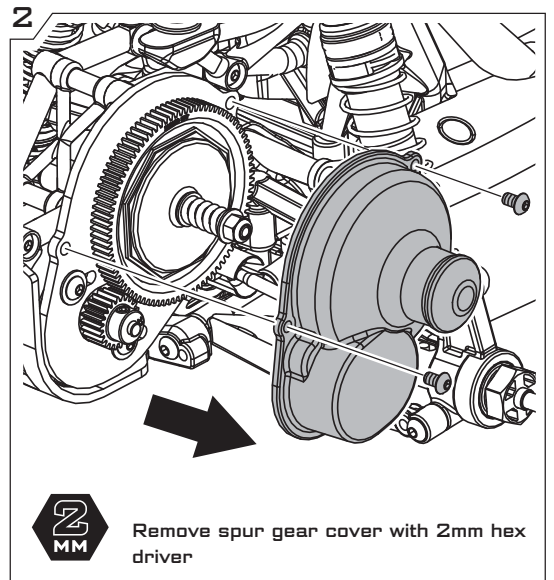
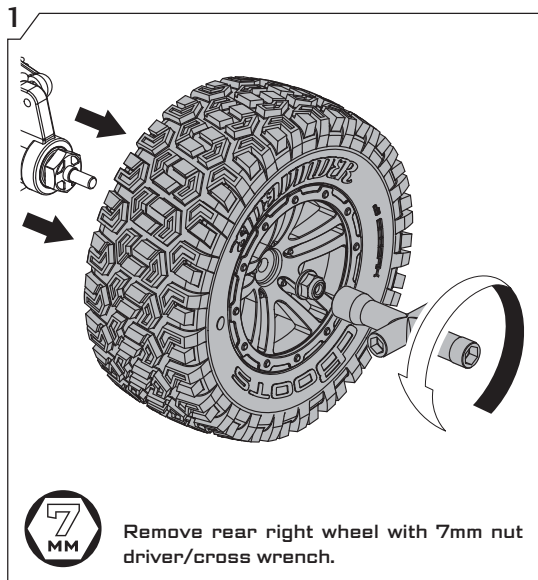

Pinion Gear Removal

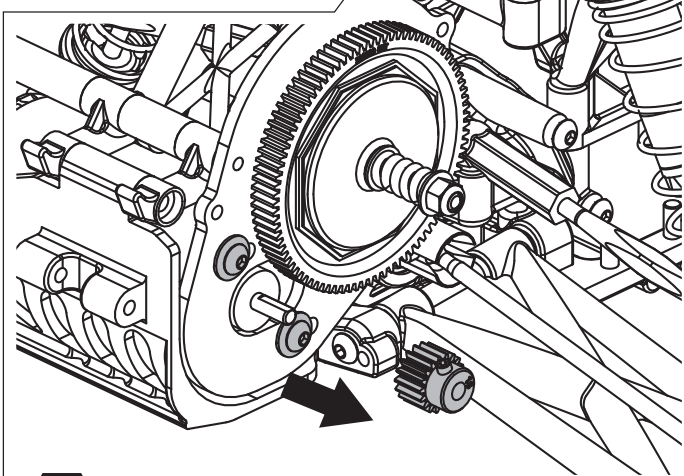

Loosen motor bolts with 2mm hex driver and loosen pinion gear grub screw with 1.5mm hex driver. Remove pinion. Fit new pinion and set gear mesh (page 13). Refit spur gear cover and wheel.

Spur Gear Removal

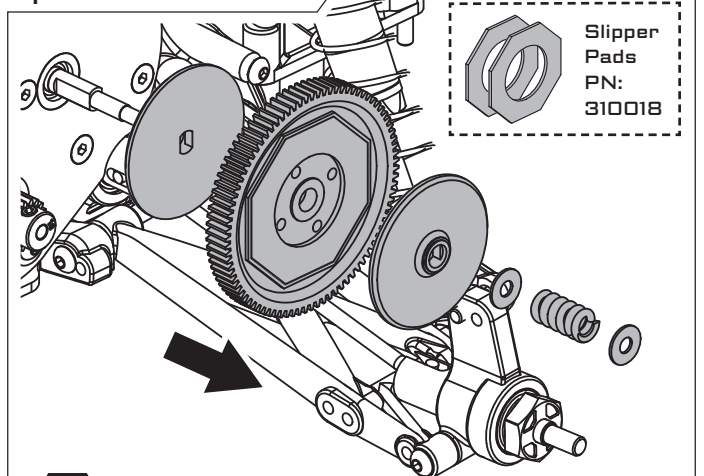

Loosen motor bolts with 2mm hex driver. Undo slipper nut with 5.5mm nut driver or cross-wrench. Remove slipper clutch mechanism and spur gear. Fit new spur gear, set gear mesh and adjust slipper (page 13). Refit spur cover and wheel.

Once you replaced the pinion or spur gear ensure you have set the gear mesh correctly - see page 13 for details.

Motor Removal



Removing the motor is useful for cleaning the motor and also if choosing to upgrade to either a different specification brushed motor or the awesome power of an ARRMA GIGA brushless system! To see what motor upgrades are available for your car please visit ARRMA-RC.com or your local ARRMA distributor.

Tools Required

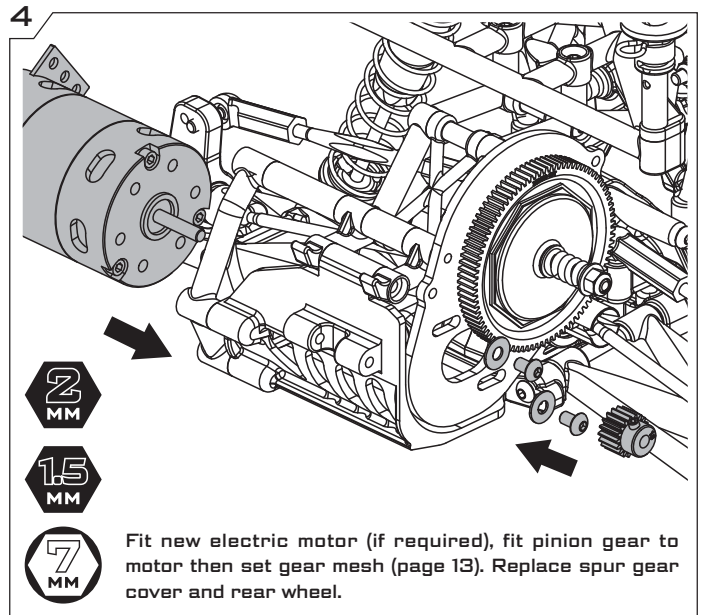
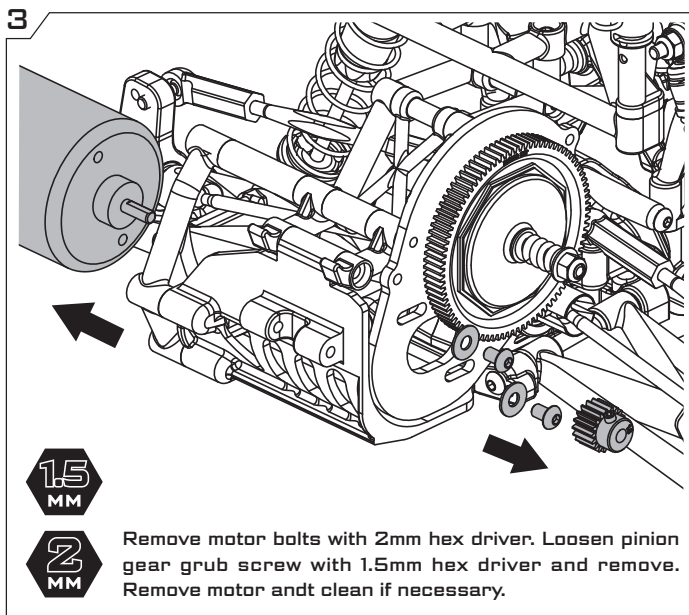
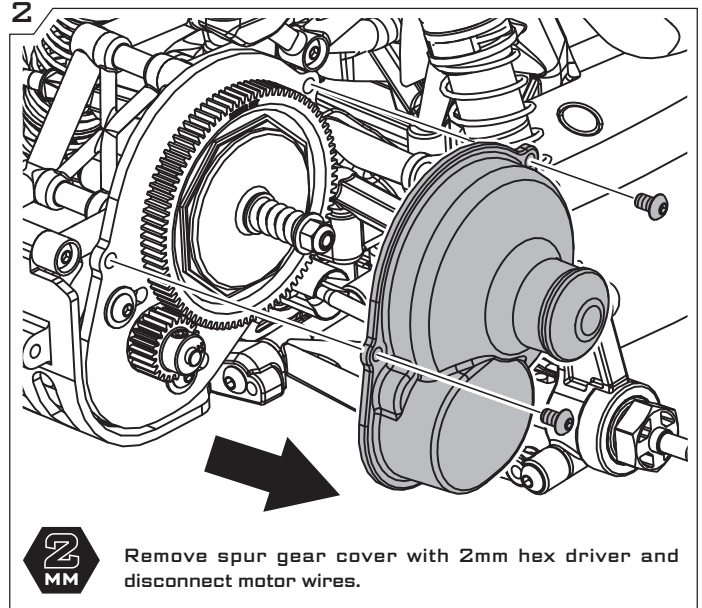
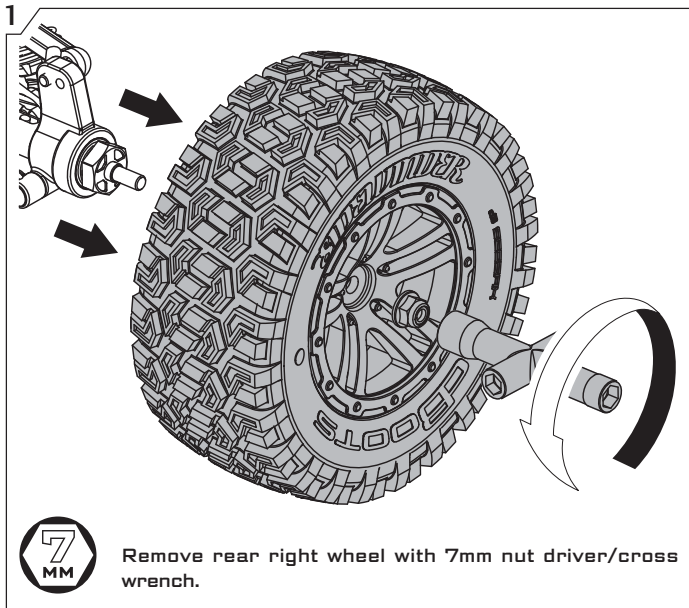
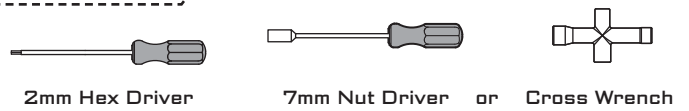

Differential Tuning

When turning a corner the inside wheel travels a shorter distance than the outside wheel. A differential allows the wheels to turn at different speeds and take a corner more quickly.

Without a differential, on a high grip surface, the inside wheel will lose traction and cause you to spin-out. This effect is less noticeable on loose surfaces, however a well setup differential will make the car easier to drive and give more predictable handling at speed.

The differential is filled with silicone oil and the thickness of this alters the operation of the differential unit. As standard, your differential is designed to provide safe, fun handling - for advice on which oil to use please visit the forums at GOFORIT-RC.com

OIL WEIGHT	CHARACTERISTIC
Thinner (Lower CST)	Looser differential action
	Less stable under braking (into corners)
	Faster steering into corner
	More steering in corner
	Greater chance of oversteer
	More chance of wheelspin
Thicker (Higher CST)	Less forward drive out of corner (in low grip conditions)
	Generally better for low traction surfaces
	Tighter differential action
	More stable braking (into corner)
	Slower steering into corner
	Less steering in corner
	Greater chance of understeer
	Less chance of wheelspin
	More forward drive out of corner
	Generally better for high traction surfaces

Differential Removal and Replacement



Tools Required

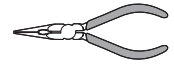
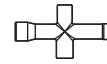

1.3mm Hex Driver

2mm Hex Driver

2.5mm Hex Driver

7mm Nut Driver

or Cross Wrench

Long-nose Pliers

1

X2 L&R

7 MM

Remove rear wheels with 7mm nut driver/cross wrench. Disconnect motor wires.

2

X2 L&R

Separate both rear camber-link ball joints with long-nose pliers.

3

X2 L&R

Remove driveshafts on both sides. Use this opportunity to inspect axles and driveshafts for wear (Page 15).

4

2.5 MM

2 MM

Remove long motor guard bolt with 2.5mm hex driver. Remove two short motor guard bolts and four gearbox/chassis bolts with 2mm hex driver.

5

2 MM

Remove two rear shock tower screws and two motor guard screws with 2mm hex driver.

6

Hinge motor guard up and remove gearbox.

Differential Removal and Replacement (cont.)

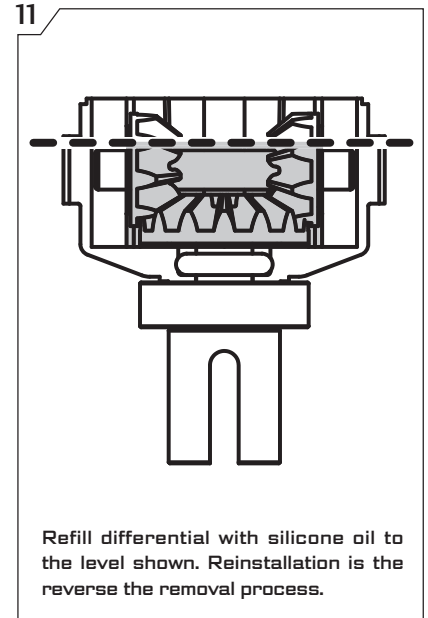
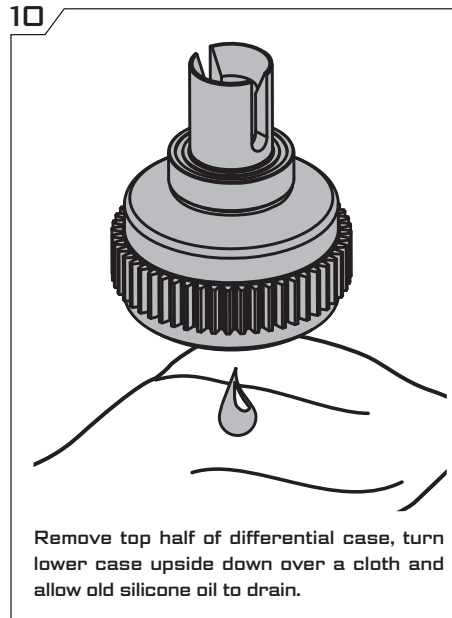
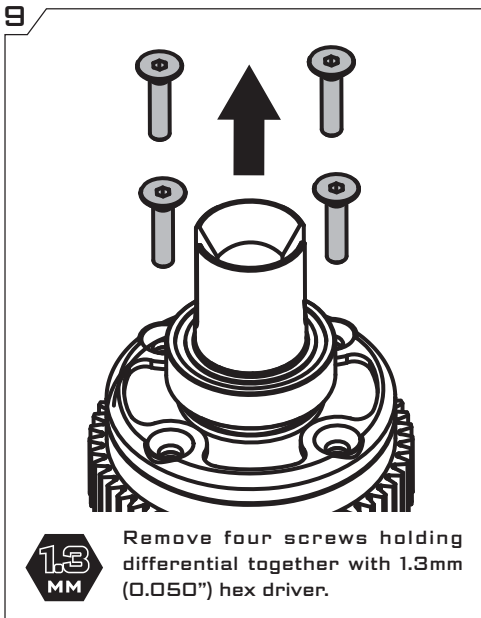
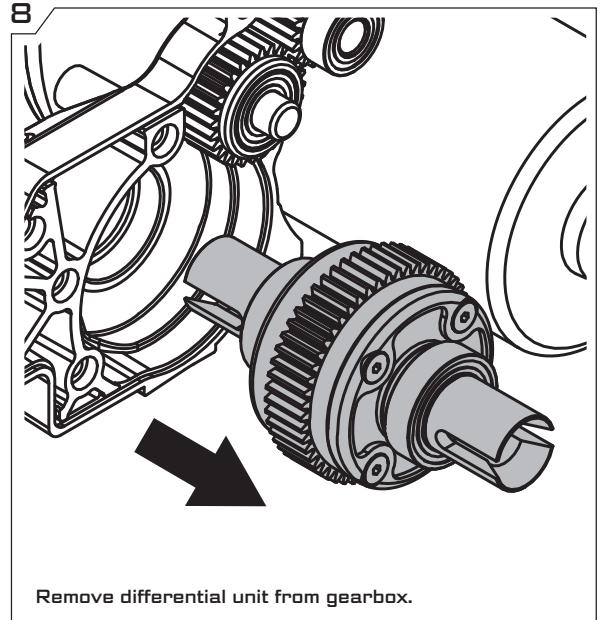
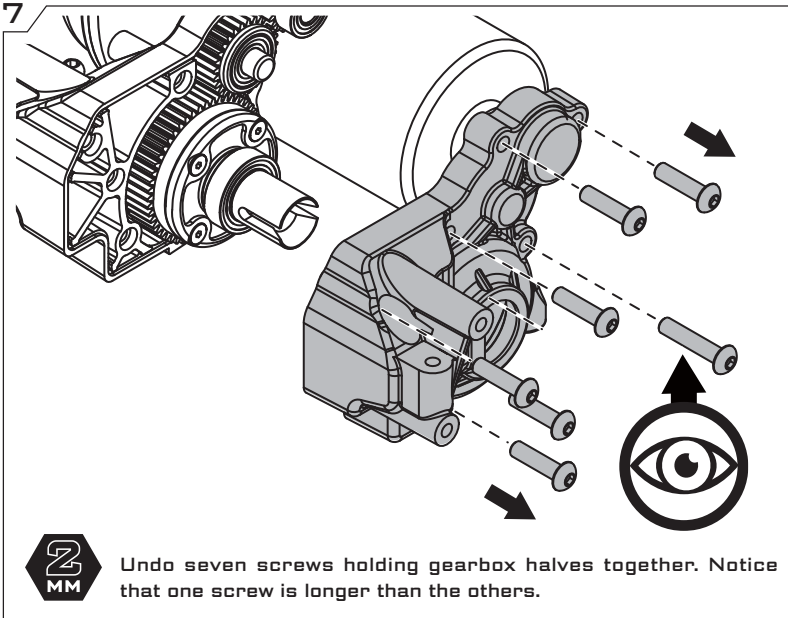

Differential Exploded View

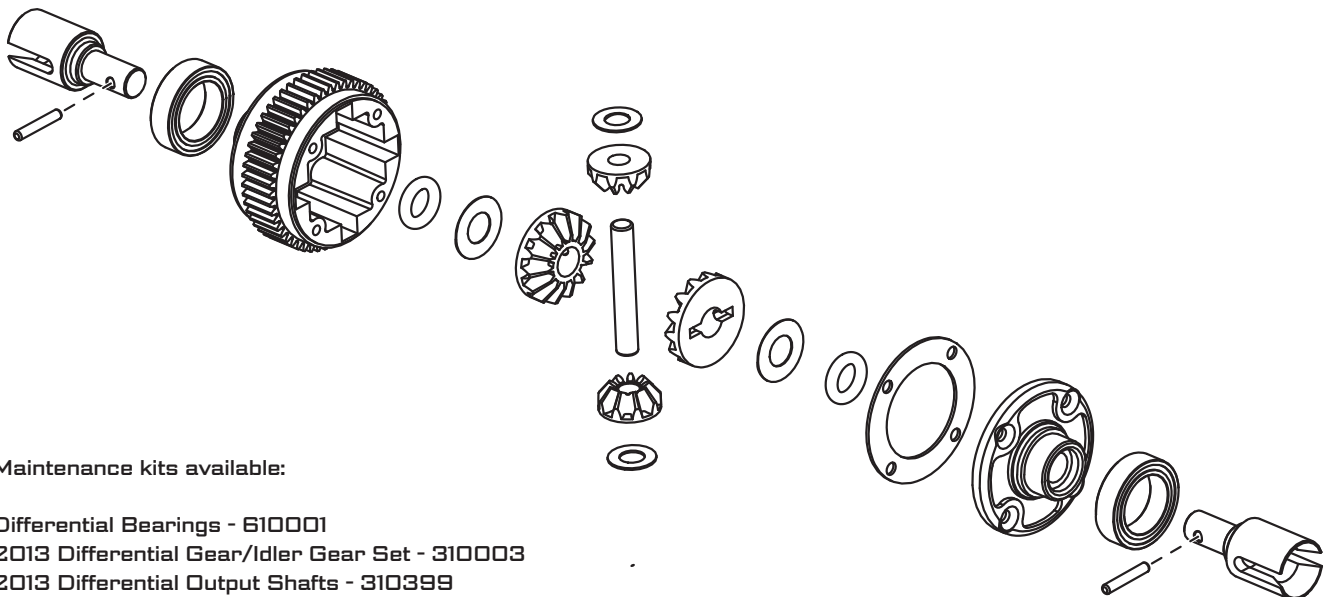



Radio-gear Maintenance

Receiver Access



Tools Required



2mm Hex Driver

If you want to replace or upgrade the steering servo, ESC (electronic speed controller) or re-bind the transmitter, you will need to access the receiver.

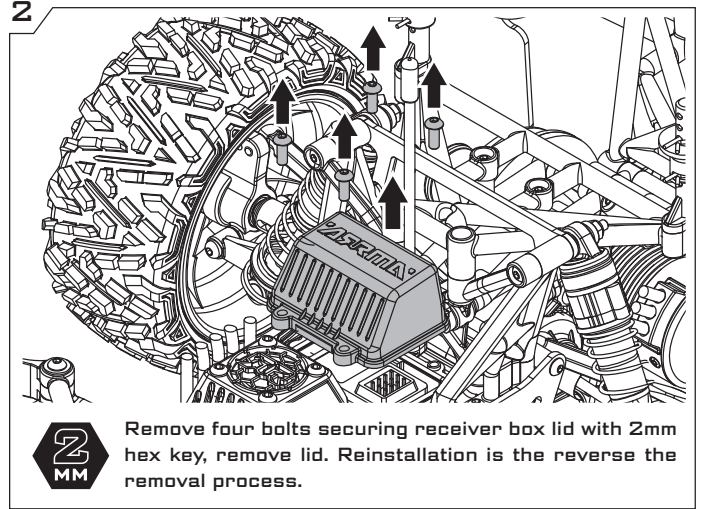
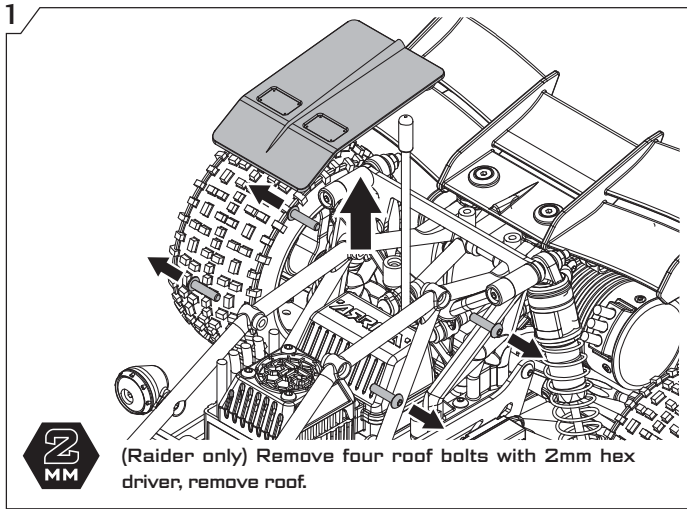

Steering Maintenance

Steering Access



If you find your car's steering feels loose it may mean you have to adjust the servo saver. To do this you will have to get access to the steering mechanism.

Tools Required

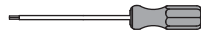

2mm Hex Driver



7mm Nut Driver or

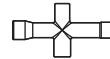

Cross Wrench

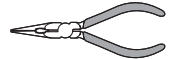

Long-nose Pliers

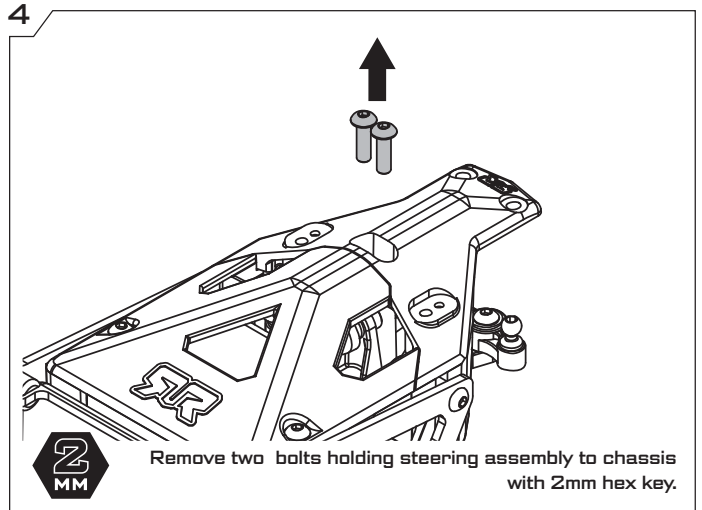
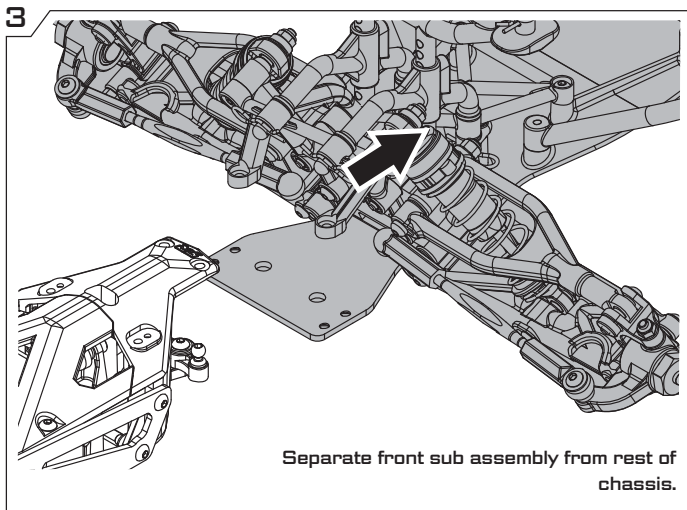
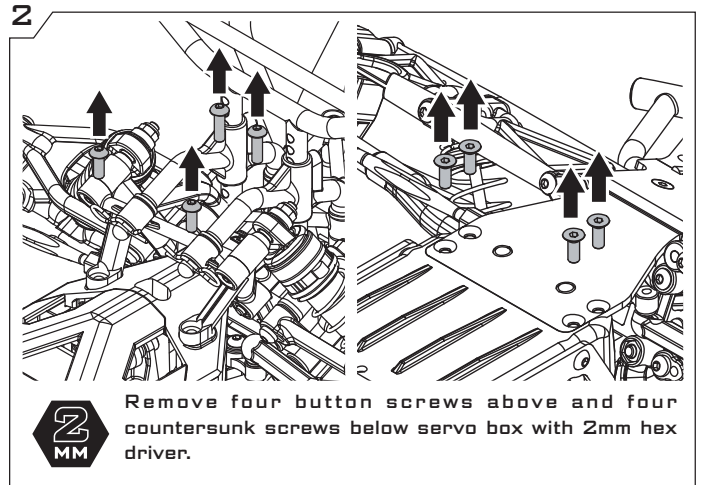
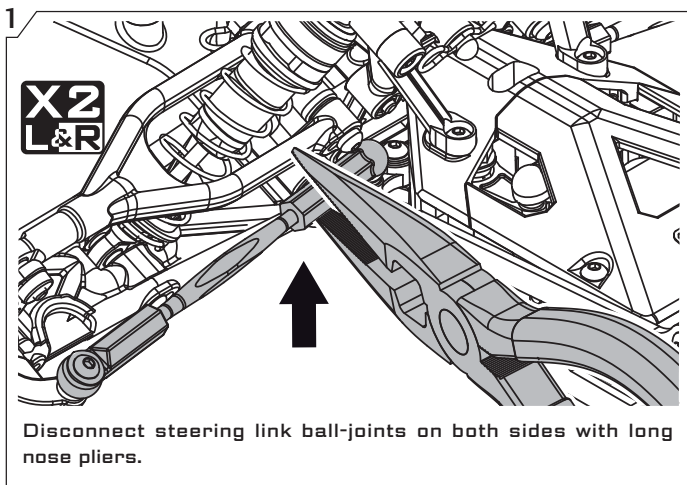

Steering Access (cont.)

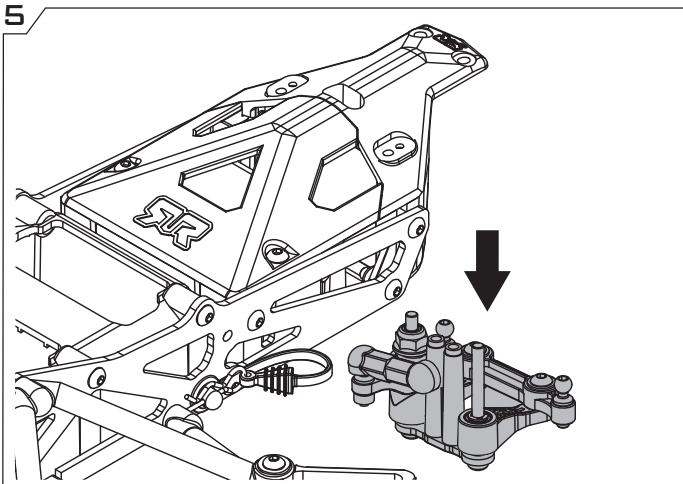

Disconnect servo arm ball-joint and remove steering assembly from servo box.

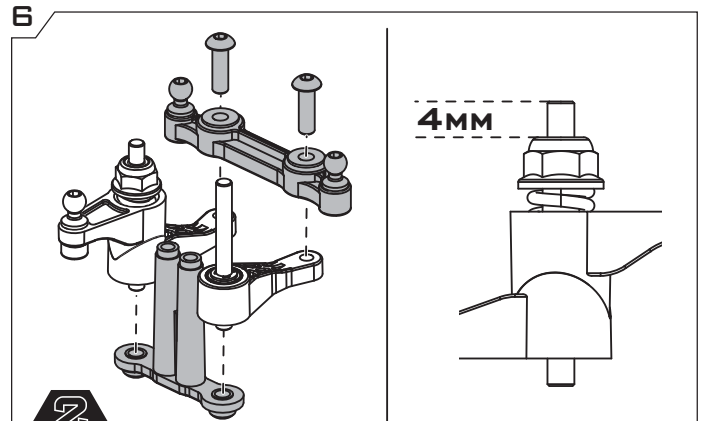

2
MM

7
MM

Inspect servo saver, ensuring that it is set to the factory setting above. Set with 7mm hex driver. Reassembly is the reverse the removal process.

Servo Removal

Tools Required



2mm Hex Driver



Upgrading your servo will give quicker and more powerful steering.

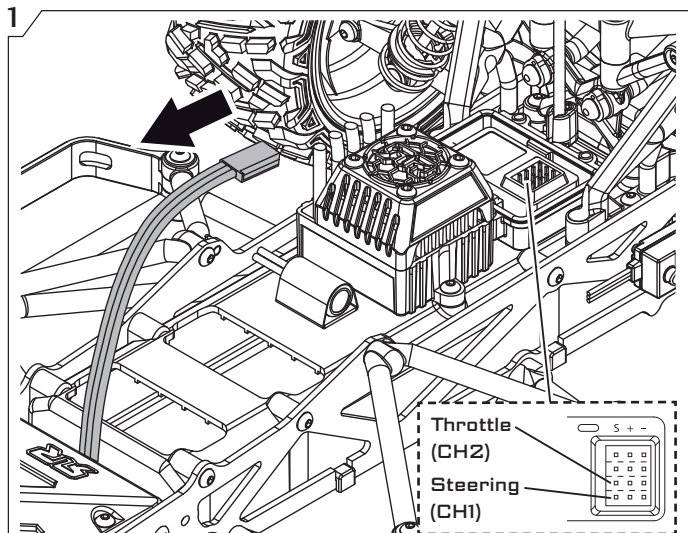

Access the receiver (page 25); unplug the steering servo wire (CH1) and remove the wire from the receiver box.

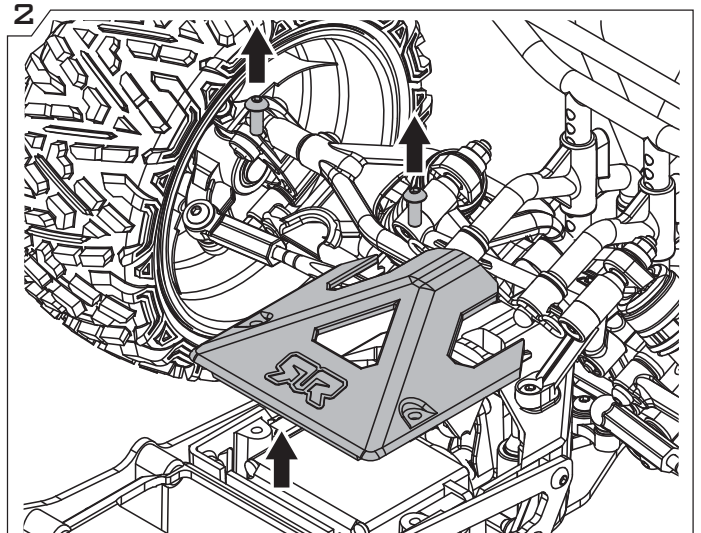

2
MM

Remove the two servo box cover bolts with a 2mm hex key and remove the cover.

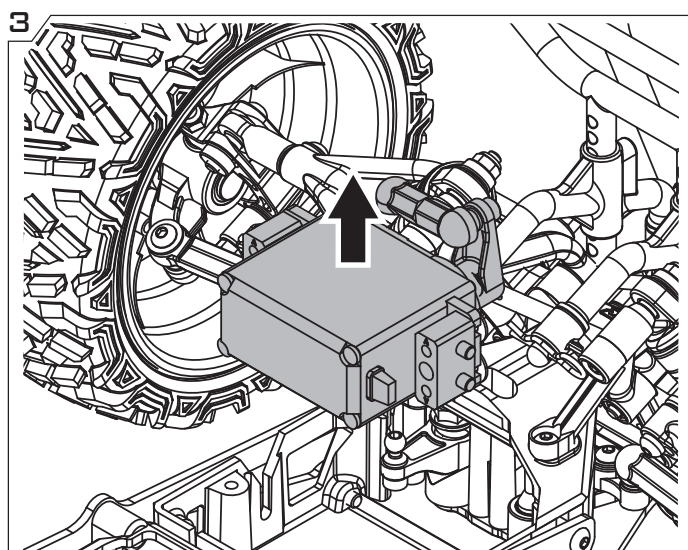

Disconnect the steering ball joint and lift the servo assembly from the chassis.

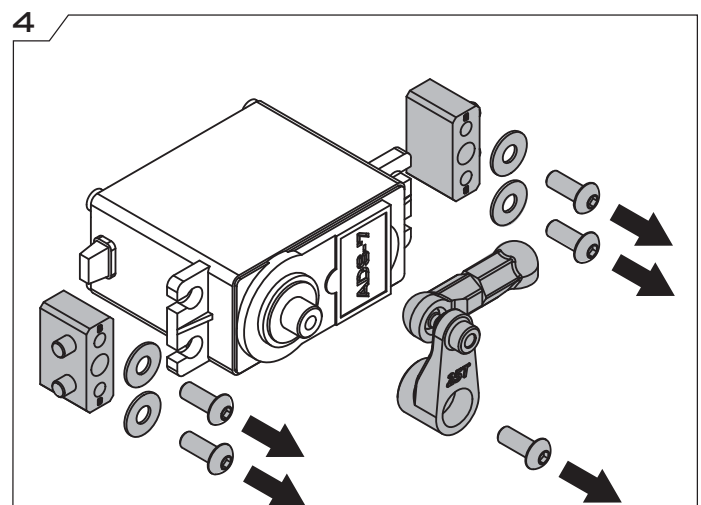

2
MM

Note mount spacing and servo arm position. Remove mount and arm bolts with a 2mm hex key.

FRONT VORNE AVANT DELANTERO フロント 前

RAIDER/ADX-10

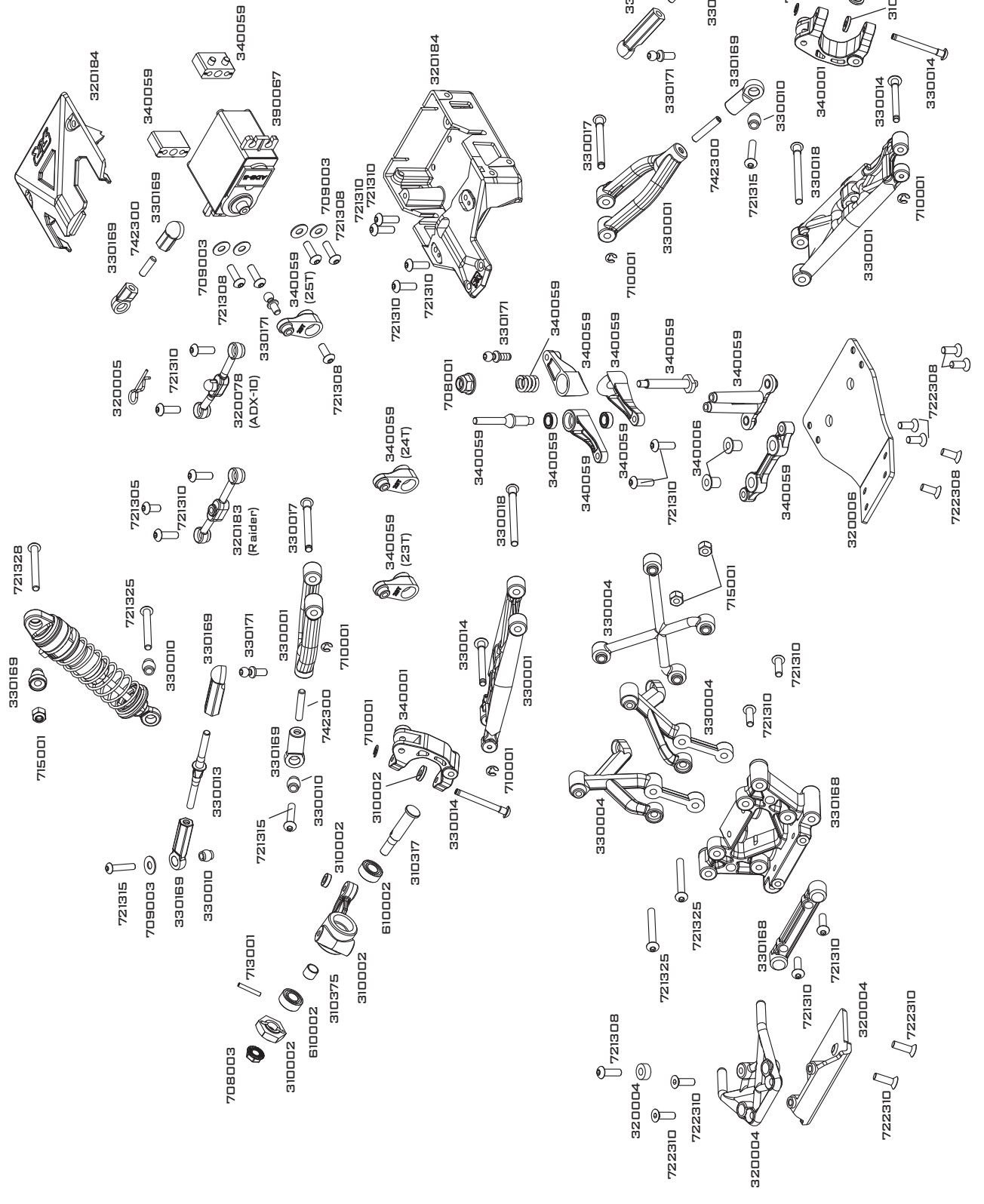
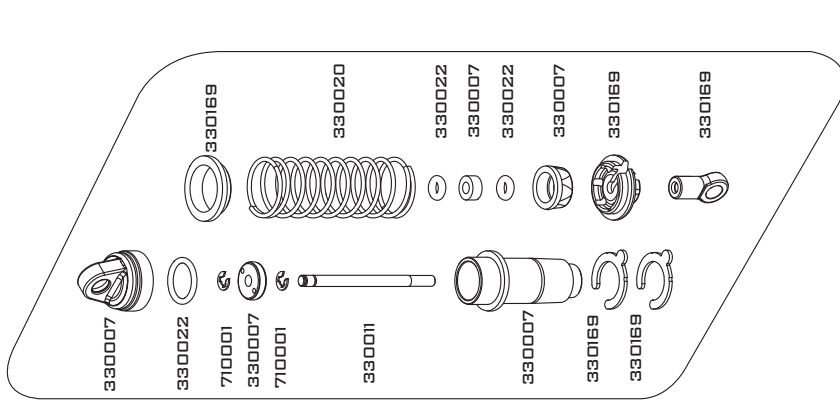

CENTRE
CENTER
CENTRO
中心
RAIDER/ADX-10

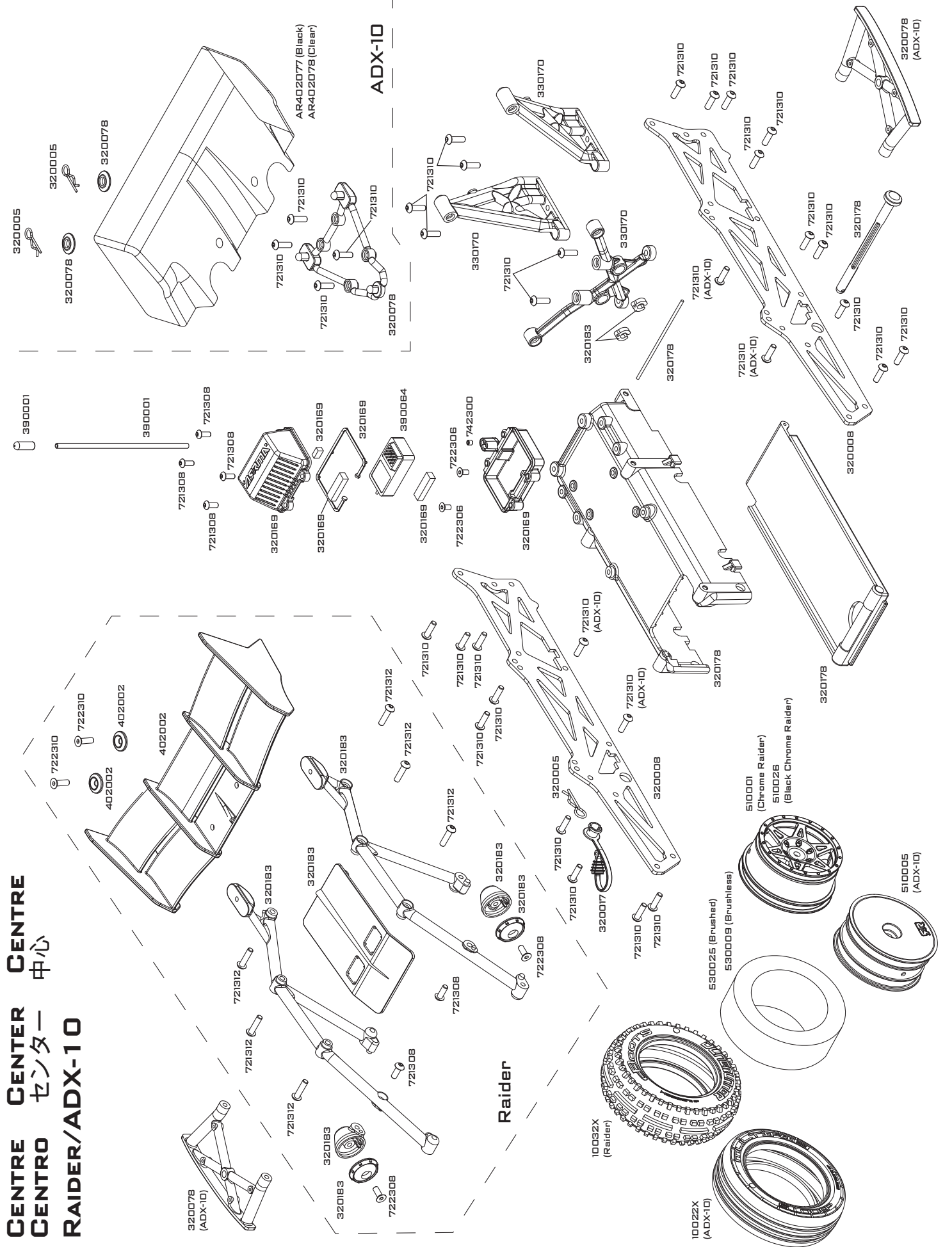

CENTRE
CENTRO
GRANITE/VORTEX

CENTRE
中心

CENTER
センター

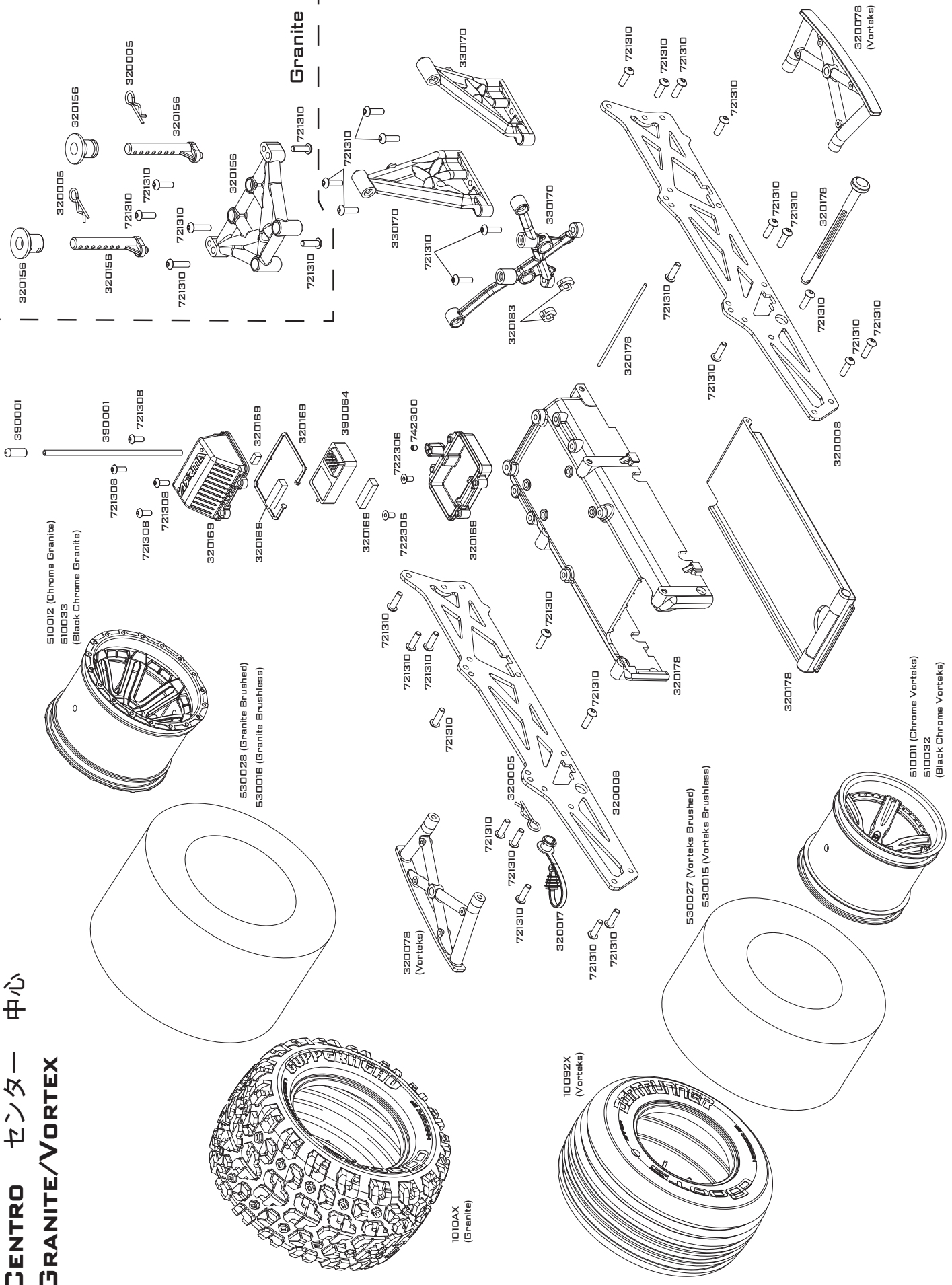

Granite

530028 (Granite Brushed)
 530016 (Granite Brushless)

530027 (Vortexes Brushed)
 530015 (Vortexes Brushless)

510011 (Chrome Vortexes)
 510032 (Black Chrome Vortexes)

320078 (Vortexes)

1010AX (Granite)

10092X (Vortexes)

REAR HINTEN ARRIÈRE TRASERO リア 后
GRANITE/VORTEKS

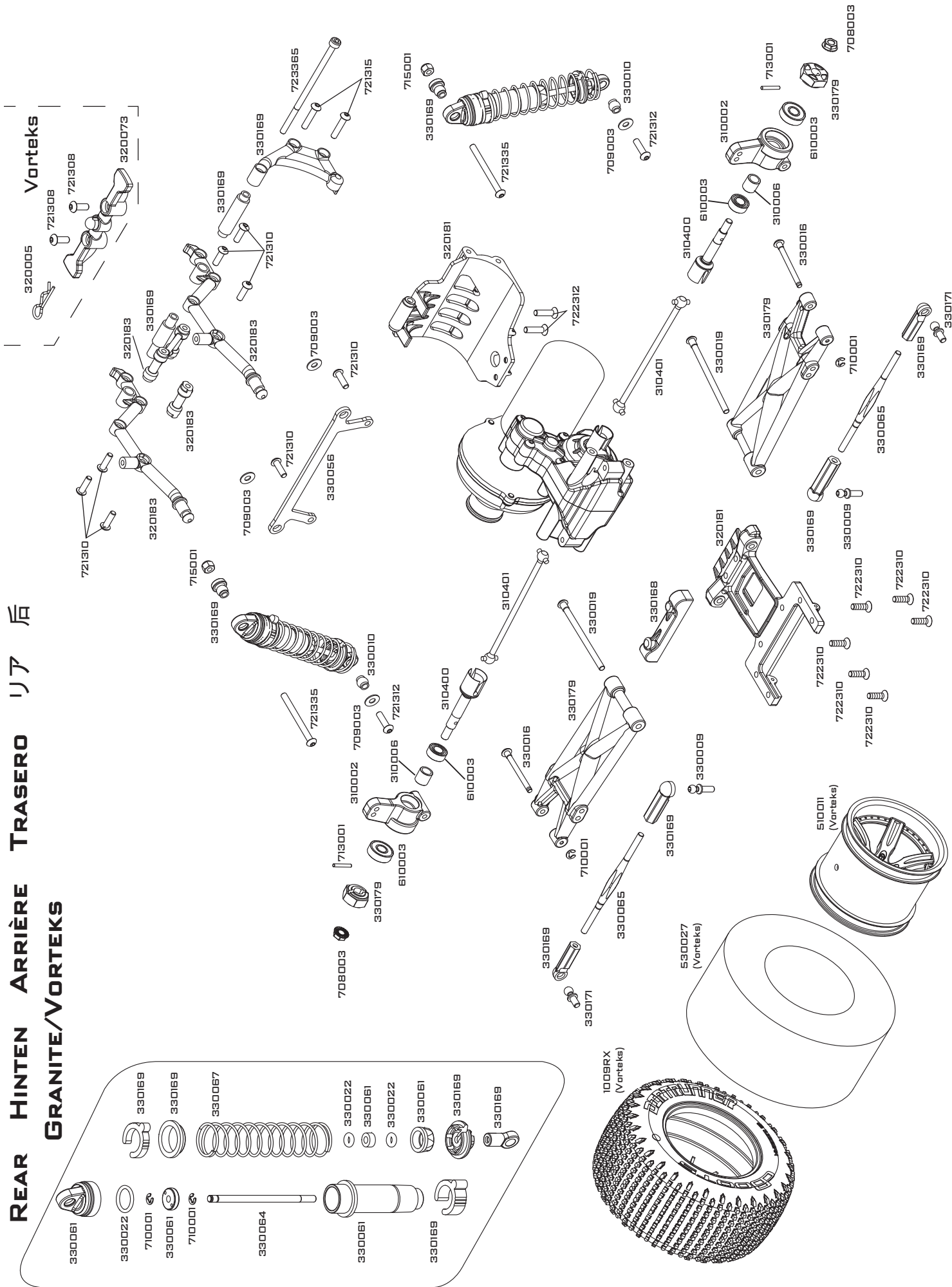

REAR HINTEN ARRIÈRE TRASERO リア 后
 FURY/MOJAVE

Exploded View Explosionszeichnungen Vues Éclatées Plano De Despiece 展開図 爆炸图

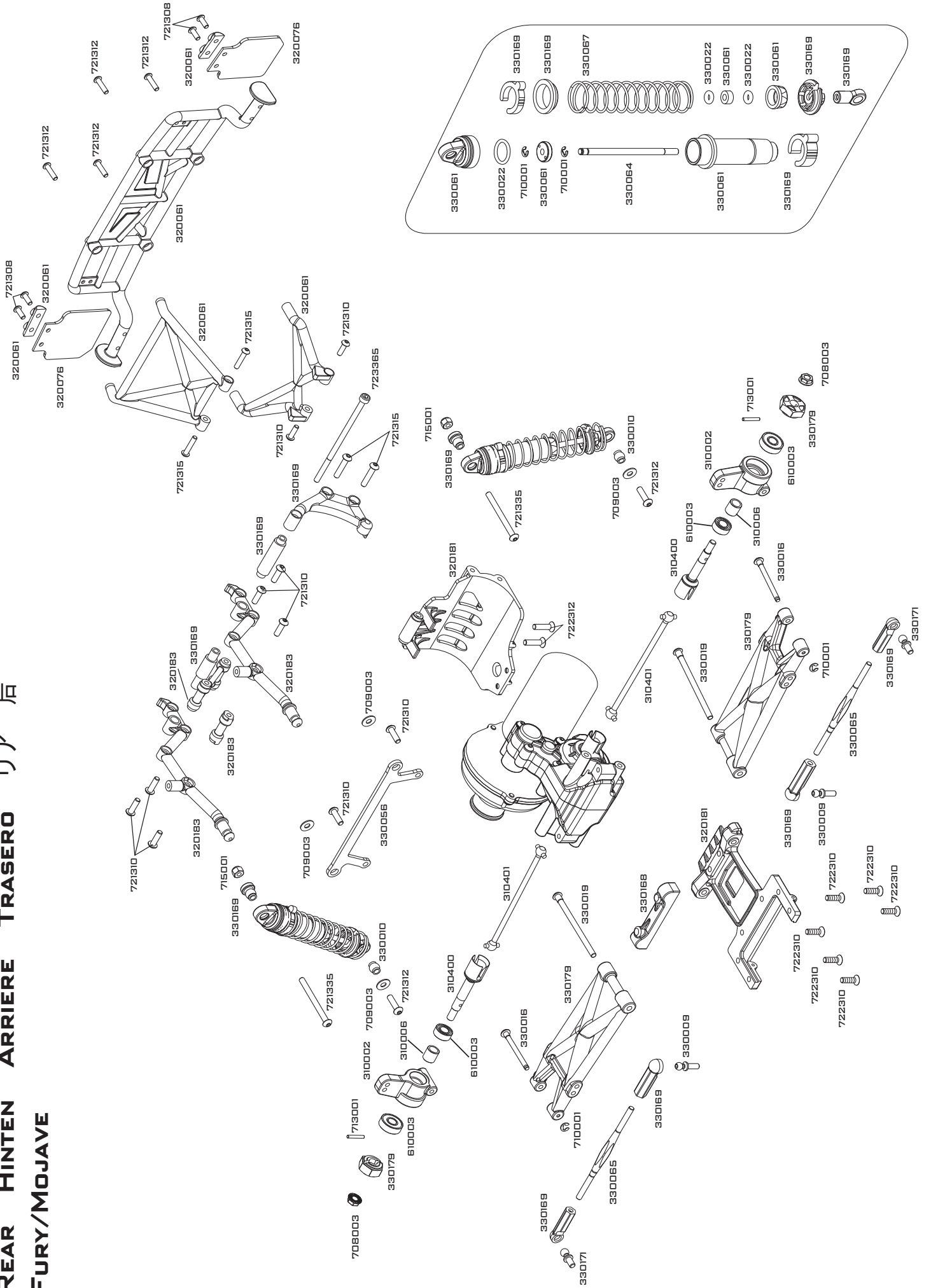

OPTION PARTS AND UPGRADES

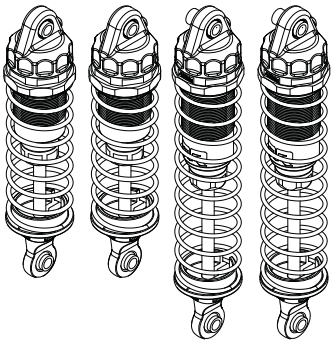

AR220014
(Raider/ADX-10)

Option Shocks Short

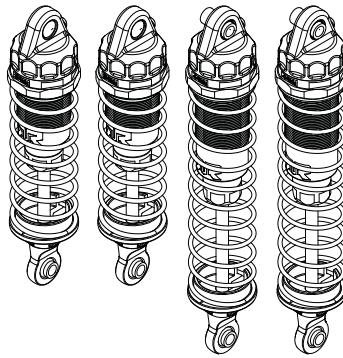

AR220015
(Fury/Mojave/Granite/Vorteks)

Option Shocks Long

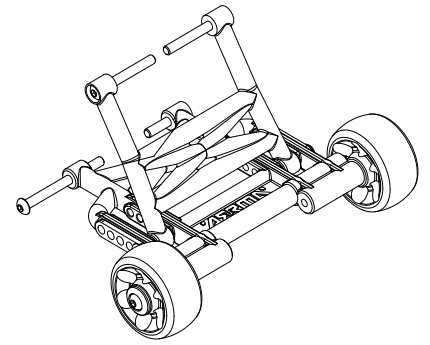

AR320165

Wheelie Bar Set

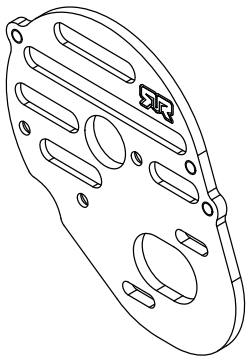

AR310394

Alloy Heatsink Motor Plate

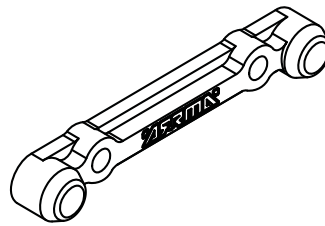

AR320157

Alloy Front Hinge pin Brace

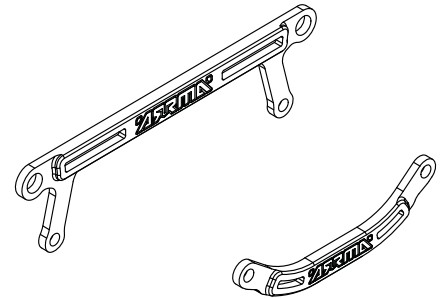

AR330148 (Front)
Alloy Shock Tower Braces

AR320162 (Rear)

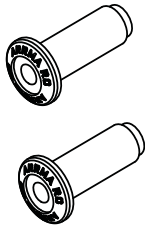

AR320186

Alloy Wheelie Bar Axles

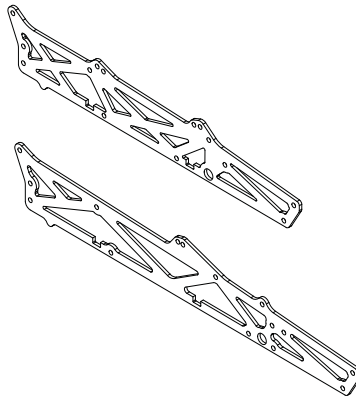

AR320174 (SWB)
Red Chassis TVPs

AR320175 (LWB)

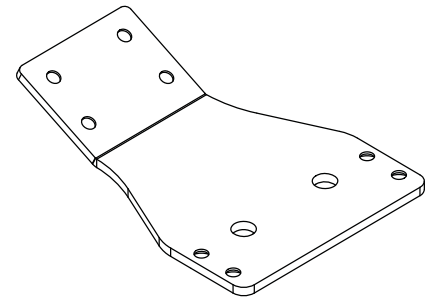

AR320176

Red Front Chassis Plate



AR340055 (23T)
AR340057 (25T)
Alloy Servo Arms

AR340056 (24T)



RAIDER

Settings

Front

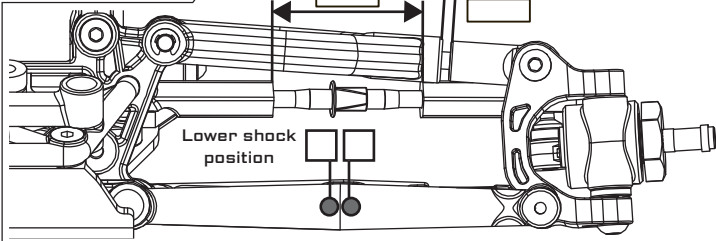

Ride Height _____ mm

Camber _____ °

Toe Angle _____ °

Shocks

	FRONT	REAR
Piston	_____	_____
Oil wt.	_____	_____
Spring	_____	_____

Rear

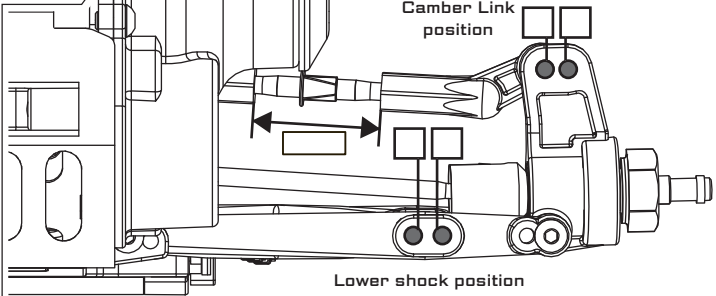

Ride Height _____ mm

Camber _____ °

Differential

Oil wt. _____

Motor/Gears

Motor	_____	Spur Gear	_____
ESC	_____	Pinion Gear	_____

ADX10

Settings

Front

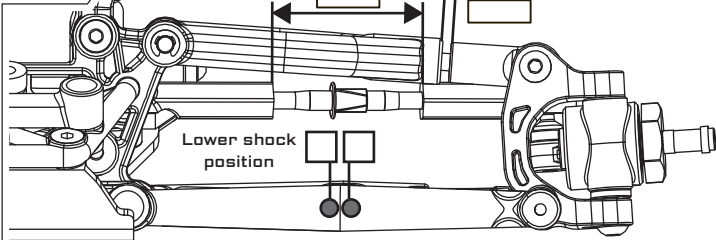

Ride Height _____ mm

Camber _____ °

Toe Angle _____ °

Shocks

	FRONT	REAR
Piston	_____	_____
Oil wt.	_____	_____
Spring	_____	_____

Rear

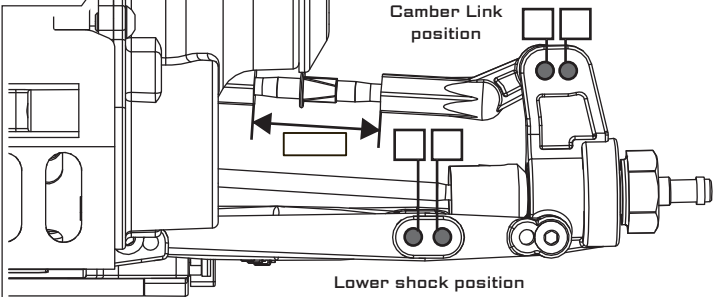

Ride Height _____ mm

Camber _____ °

Differential

Oil wt. _____

Motor/Gears

Motor	_____	Spur Gear	_____
ESC	_____	Pinion Gear	_____

FURY

Settings

Front

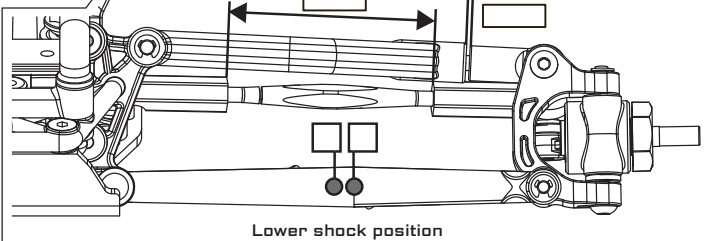

Ride Height _____ mm

Camber _____ °

Toe Angle _____ °

Shocks

	FRONT	REAR
Piston	_____	_____
Oil wt.	_____	_____
Spring	_____	_____

Rear

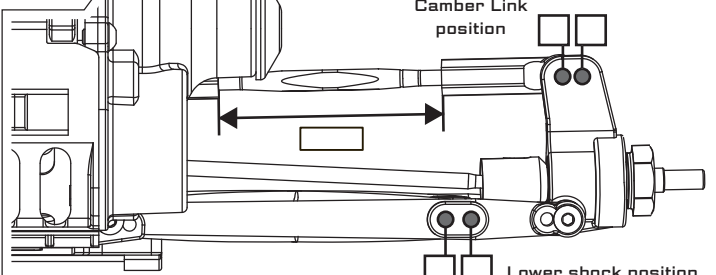

Ride Height _____ mm

Camber _____ °

Differential

Oil wt. _____

Motor/Gears

Motor	_____	Spur Gear	_____
ESC	_____	Pinion Gear	_____

MOJAVE Settings

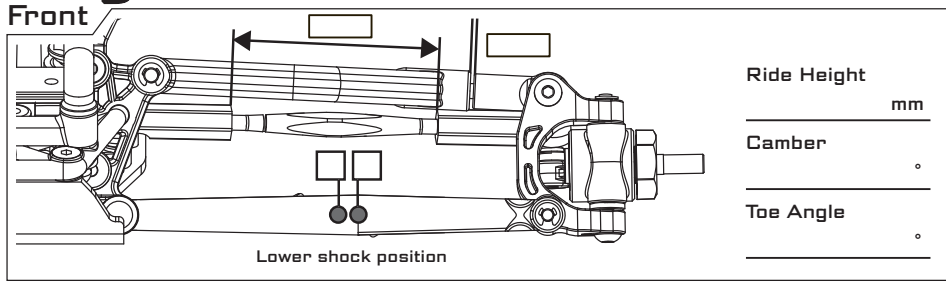

Ride Height _____ mm
 Camber _____ °
 Toe Angle _____ °

Shocks

	FRONT	REAR
Piston	_____	_____
Oil wt.	_____	_____
Spring	_____	_____

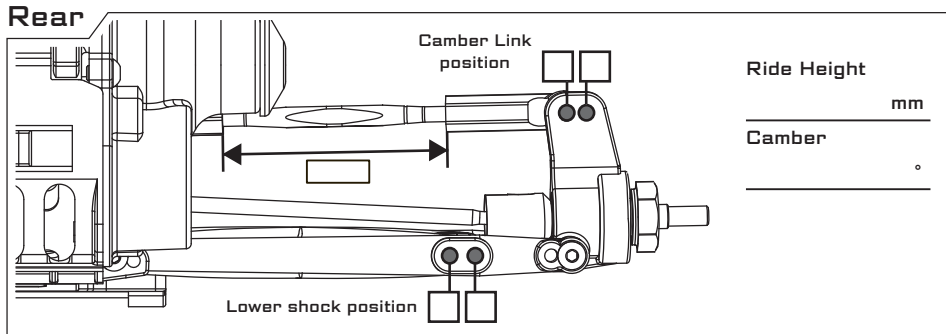

Ride Height _____ mm
 Camber _____ °

Differential

Oil wt. _____

Motor/Gears

Motor	_____	Spur Gear
ESC	_____	Pinion Gear

VORTEX Settings

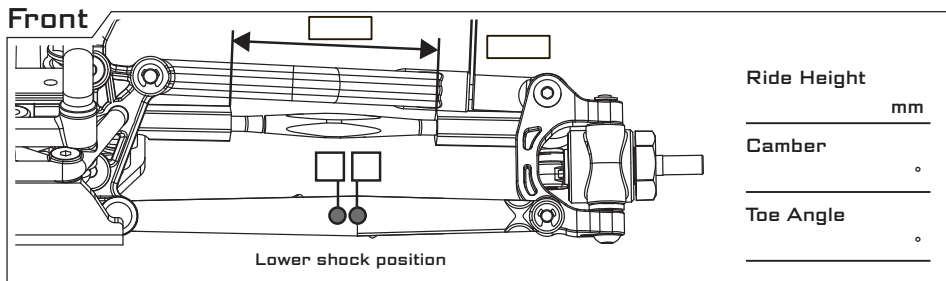

Ride Height _____ mm
 Camber _____ °
 Toe Angle _____ °

Shocks

	FRONT	REAR
Piston	_____	_____
Oil wt.	_____	_____
Spring	_____	_____

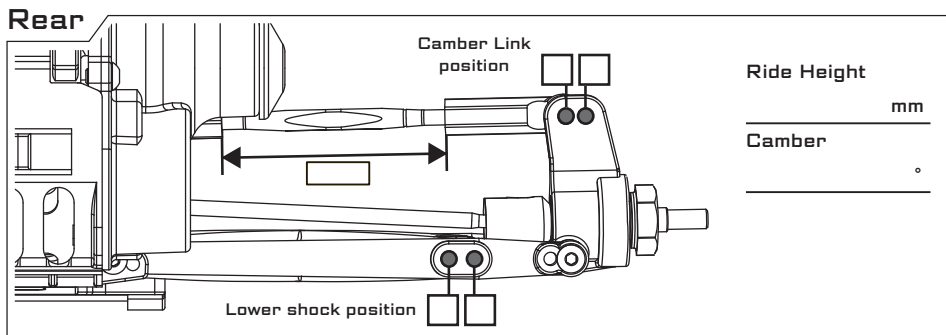

Ride Height _____ mm
 Camber _____ °

Differential

Oil wt. _____

Motor/Gears

Motor	_____	Spur Gear
ESC	_____	Pinion Gear

GRANITE Settings

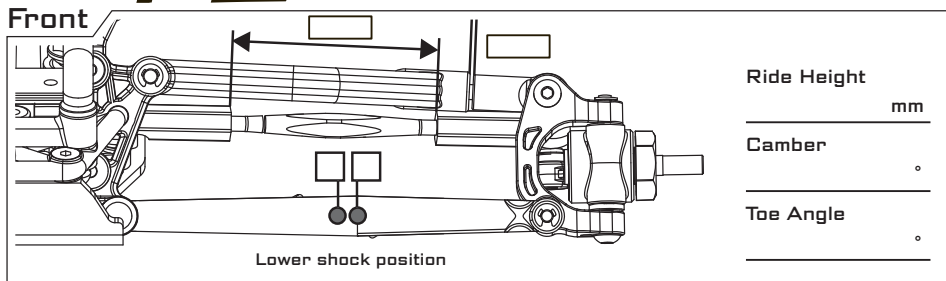

Ride Height _____ mm
 Camber _____ °
 Toe Angle _____ °

Shocks

	FRONT	REAR
Piston	_____	_____
Oil wt.	_____	_____
Spring	_____	_____

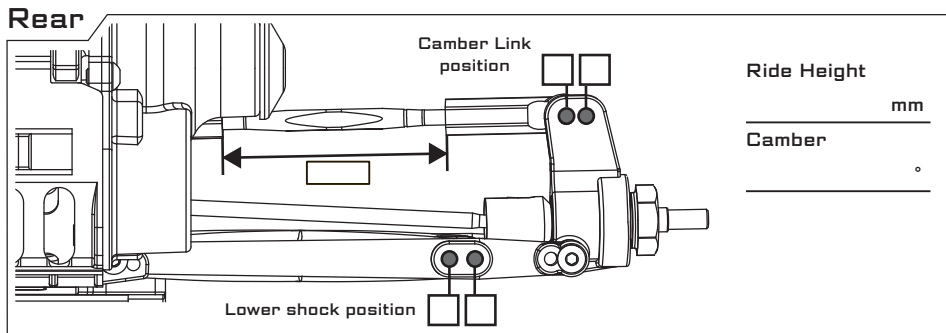

Ride Height _____ mm
 Camber _____ °

Differential

Oil wt. _____

Motor/Gears

Motor	_____	Spur Gear
ESC	_____	Pinion Gear

The background is a vibrant orange-to-red gradient with a distressed, splattered texture. It features several instances of the word 'ARRMA' in a stylized, outlined font, scattered across the frame. The central text is the most prominent, rendered in white with a thick black outline.

'ARRMA'

DESIGNED FAST DESIGNED TOUGH

ARRMA-RC.COM